

Name	Signatur	Datum	Artikelnummer	Oberfläche: Geschliffen Korn 240
Ch. Höfig	CH	03.11.2020	60197-240-OT	
Werkstoff:		Hersteller		Blattformat
1.4301 (X5CrNi18-10)		 <small>EDELSTAHL-ALUMINIUM-SCHWEIßSTEIN</small>		A4
Gewicht 0.396 kg		Maßstab: 1:1.5	Version: 1	Blatt 1 von 6

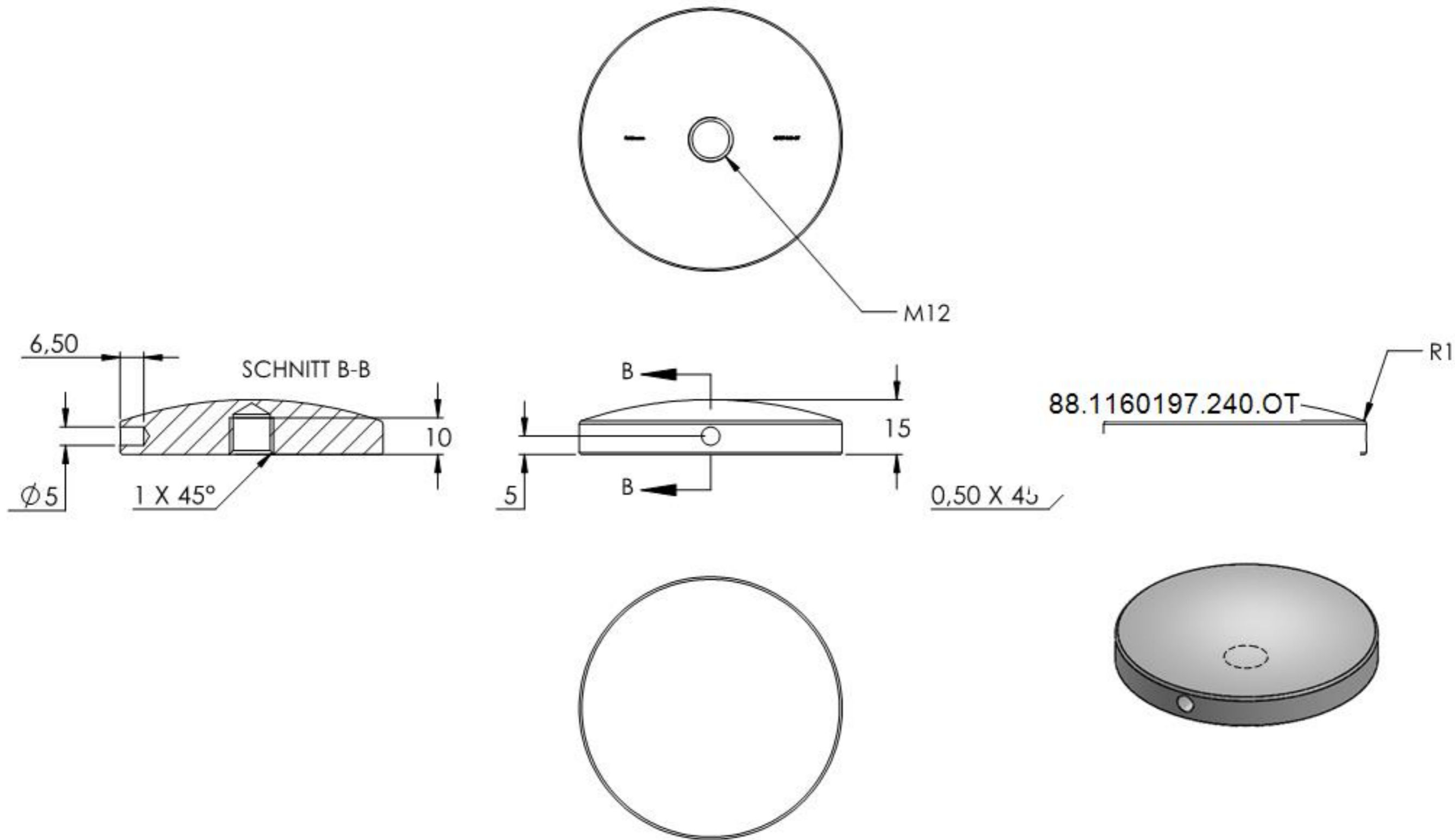

Name	Signatur	Datum	Artikelnummer	Oberfläche: Geschliffen Korn 240
Ch. Höfig	CH	03.11.2020	60197-240-OT Teil I	
Werkstoff: 1.4301 (X5CrNi18-10)			Hersteller	Blattformat
			 Feldmann EDLSTAHL-ALUMINIUM-SCHWEIßSTEIN	A4
Gewicht 0.378 kg			Maßstab: 1:1,5	Version: 1
			Blatt 2 von 6	

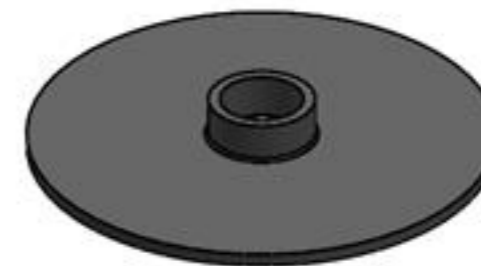
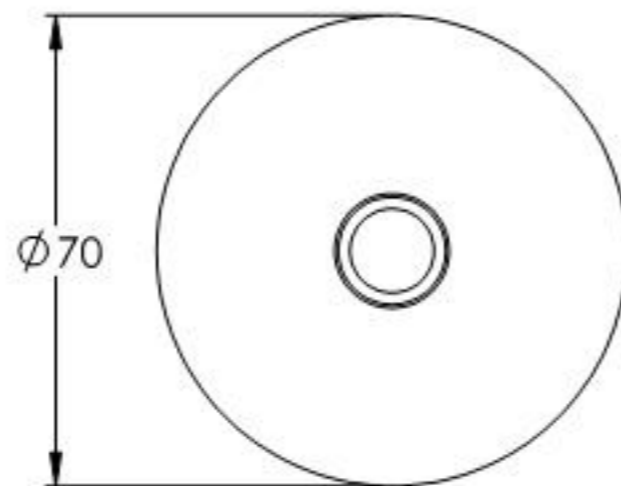
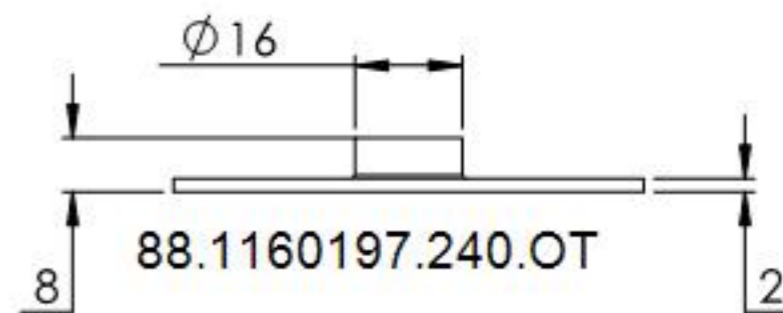
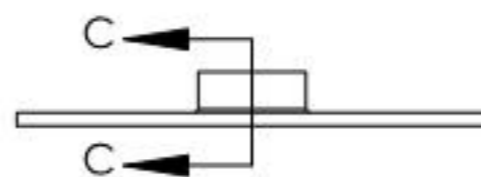
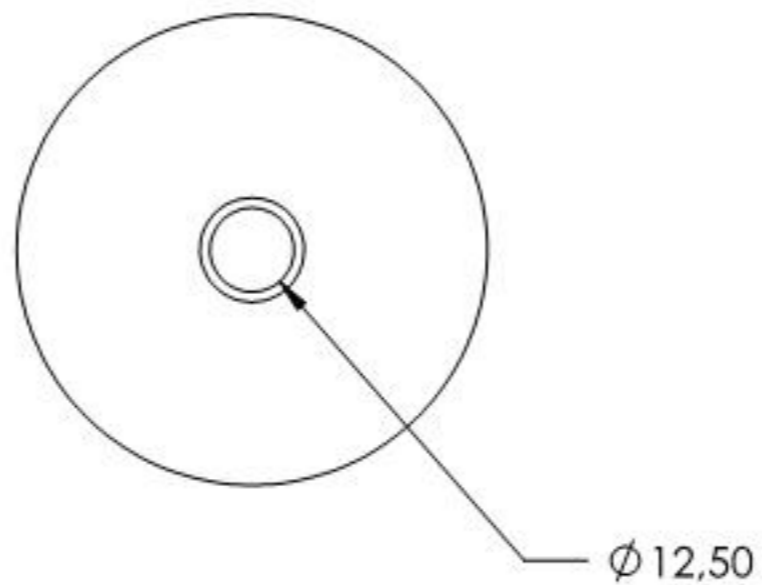
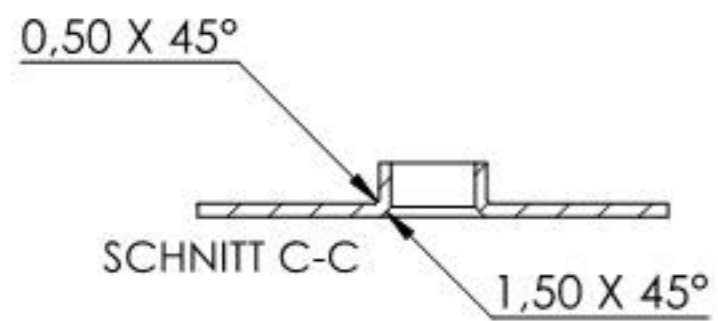

Name	Signatur	Datum	Artikelnummer	Oberfläche: Roh
Ch. Höfig	CH	03.11.2020	60197-240-OT Teil2	
Werkstoff: EPDM			Hersteller	Blattformat
			 Feldmann EDLSTAHLE-ALUMINIUM-SCHWEIßEISEN	A4
Gewicht 0.009 kg			Maßstab: 1:1,5	Version: 1
			Blatt 3 von 6	