

88.1150226.V4A.00

DIN 7991  
M8x16

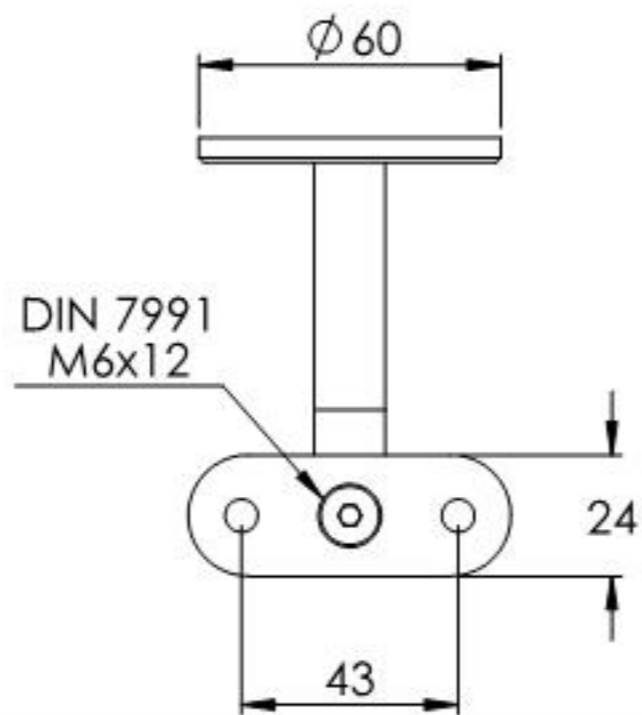

DIN 7991  
M6x12



Name	Signatur	Datum	Artikelnummer	Oberfläche: Geschliffen Korn 240
Ch. Höfig	CH	19.07.2019	50226-V4A-00	
Werkstoff:		Hersteller		Blattformat
1.4401/04 (X5CrNiMo17-12-2)		 <b>Feldmann</b> <small>EDLSTAHL-ALUMINIUM-SCHWEIßSTEIN</small>		A4
Gewicht 0.257 kg		Maßstab: 1:2	Version: 1	Blatt 1 von 5

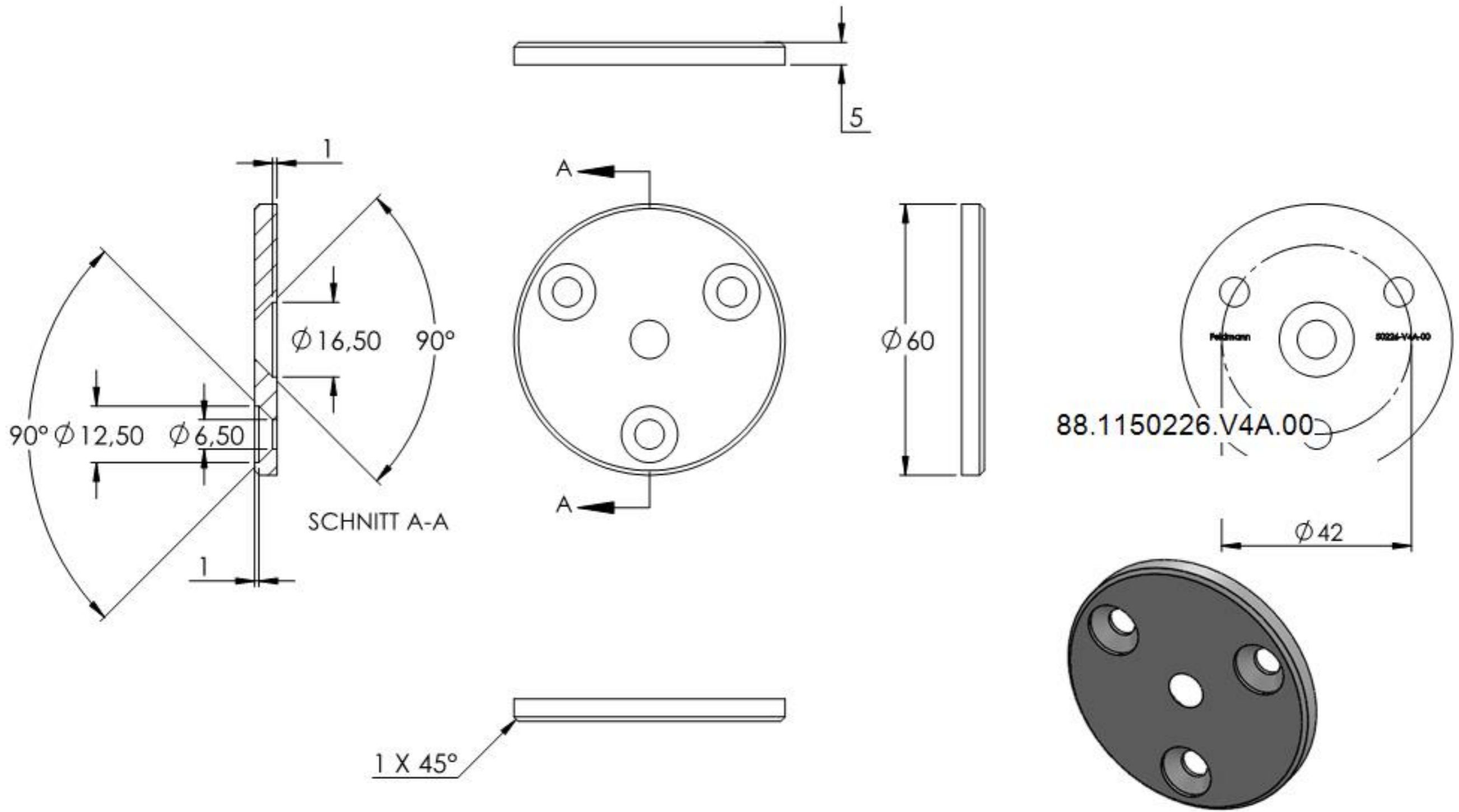

Name	Signatur	Datum	Artikelnummer	Oberfläche: Geschliffen Korn 240
Ch. Höfig	CH	19.07.2019	50226-V4A-00 Teil1	
Werkstoff:		Hersteller		Blattformat
1.4401/04 (X5CrNiMo17-12-2)		 <small>EDLSTAHLE · ALUMINIUM · SCHWEIßEISEN</small>		A4
Gewicht 0.098 kg		Maßstab: 1:1.25	Version: 1	Blatt 2 von 5

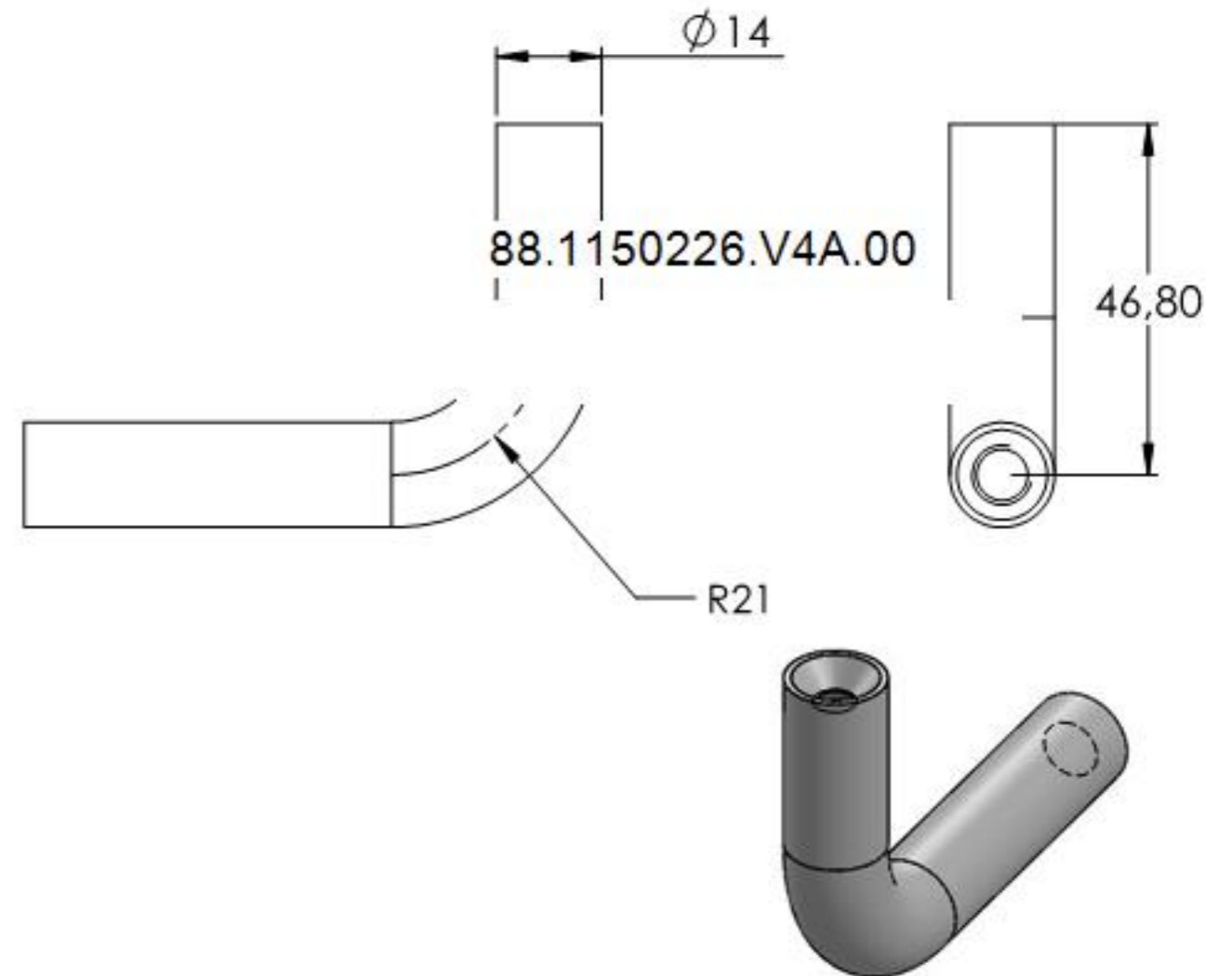
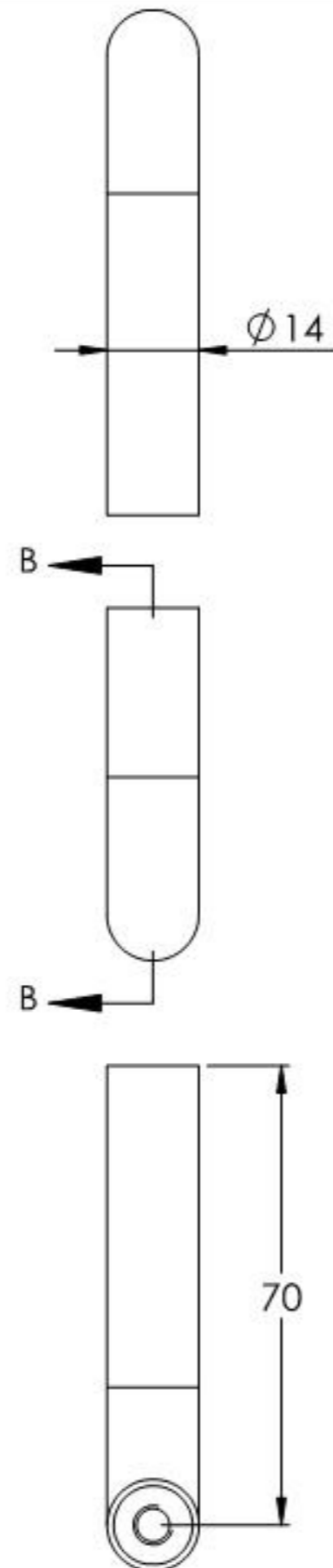
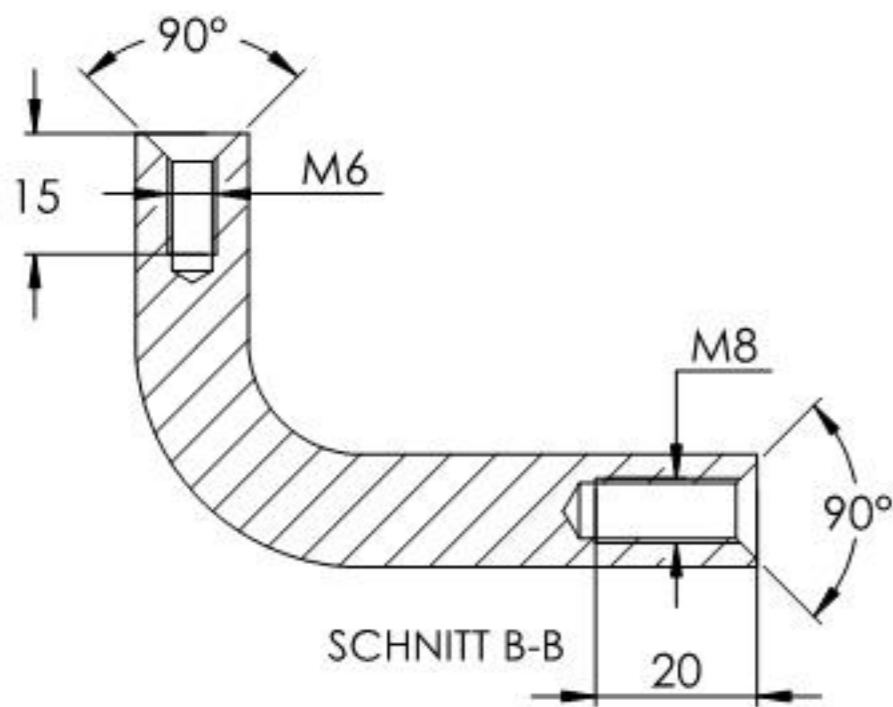

Name	Signatur	Datum	Artikelnummer	Oberfläche: Geschliffen Korn 240
Ch. Höfig	CH	19.07.2019	50226-V4A-XX Teil2	
Werkstoff:		Hersteller		Blattformat
1.4401/04 (X5CrNiMo17-12-2)		 <b>Feldmann</b> <small>EDLSTAHLE · ALUMINIUM · SCHWEIßEISEN</small>		A4
Gewicht 0.122 kg		Maßstab: 1:1.25	Version: 1	Blatt 3 von 5