

Name	Signatur	Datum	Artikelnummer	Oberfläche: Geschliffen Korn 240
Ch. Höfig	CH	19.07.2019	50226-240-00	
Werkstoff:		Hersteller		Blattformat
1.4301 (X5CrNi18-10)		 Feldmann <small>EDLSTAHL-ALUMINIUM-SCHWEIßSTEIN</small>		A4
Gewicht 0.254 kg		Maßstab: 1:2	Version: 1	Blatt 1 von 5

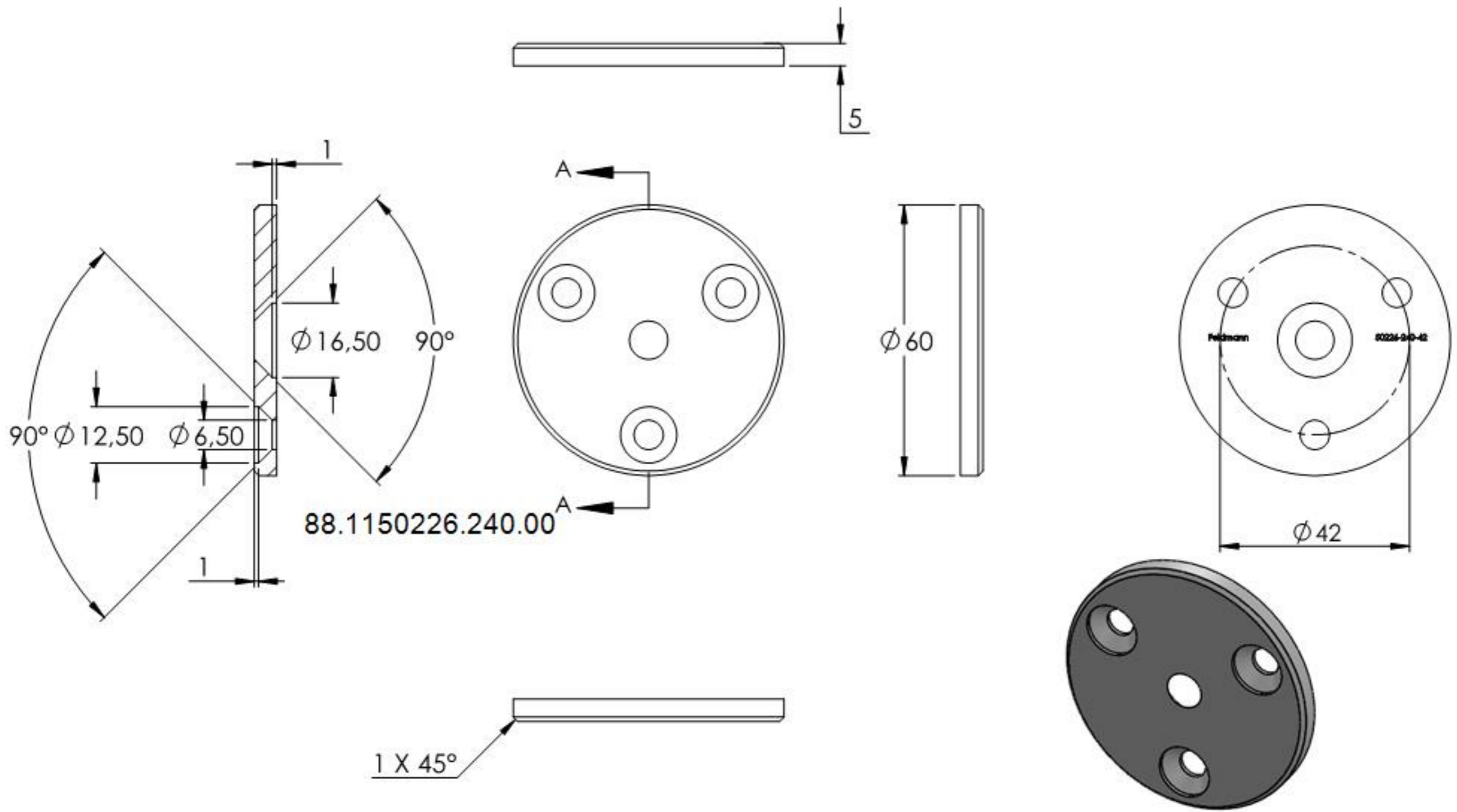

Name	Signatur	Datum	Artikelnummer	Oberfläche: Geschliffen Korn 240
Ch. Höfig	CH	19.07.2019	50226-240-42 Teil1	
Werkstoff:		Hersteller		Blattformat
1.4301 (X5CrNi18-10)		 <small>EDLSTAHLE · ALUMINIUM · SCHWEIßEISEN</small>		A4
Gewicht 0.096 kg		Maßstab: 1:1.25	Version: 1	Blatt 2 von 5

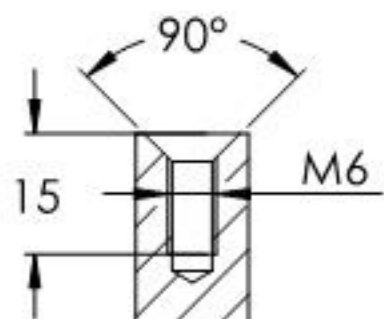

M8
88.1150226.240.00

SCHNITT B-B
20

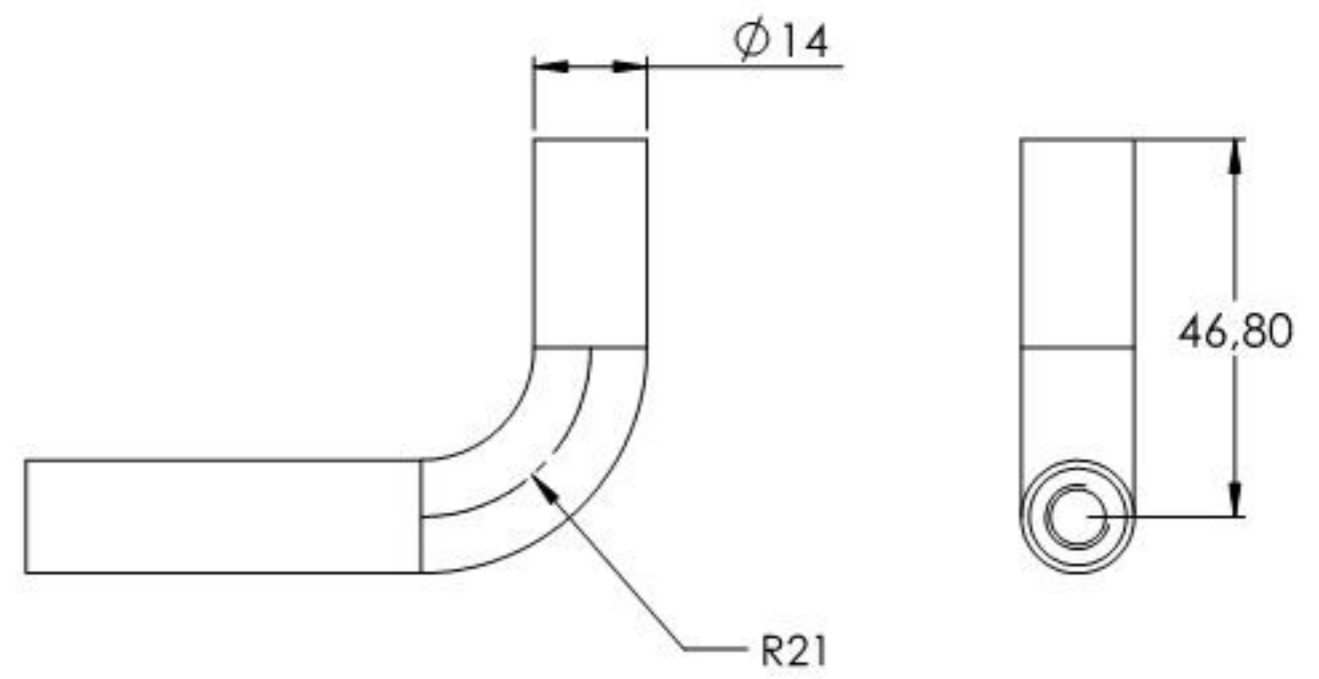
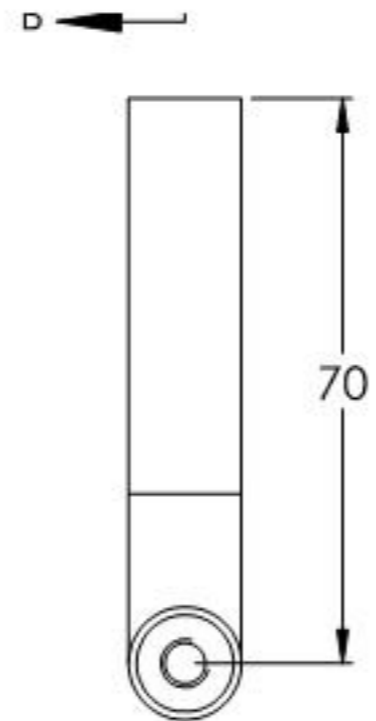
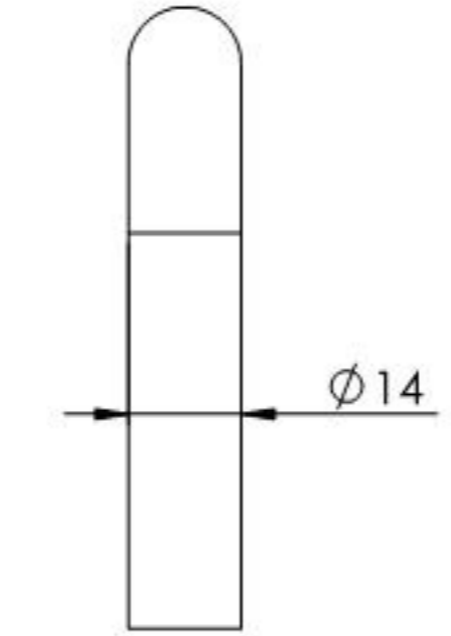

Name	Signatur	Datum	Artikelnummer	Oberfläche: Geschliffen Korn 240
Ch. Höfig	CH	19.07.2019	50226-240-XX Teil2	
Werkstoff: 1.4301 (X5CrNi18-10)		Hersteller 		Blattformat A4
Gewicht 0.120 kg		Maßstab: 1:1.25 Version: 1		Blatt 3 von 5