

88.11500.150

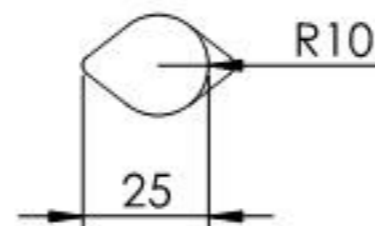

Name	Signatur	Datum	Artikelnummer	Oberfläche: Roh
Ch. Höfig	CH	21.11.2016	500-150	
Werkstoff: 1.0037 (S235JR)		Hersteller 		Blattformat A4
Gewicht 0.394 kg		Maßstab: 1:2	Blatt 1 von 6	

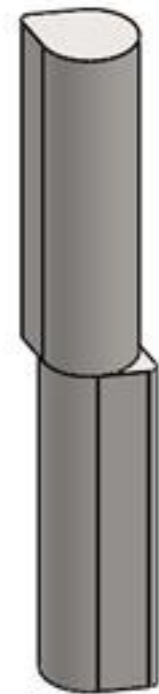
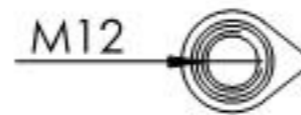
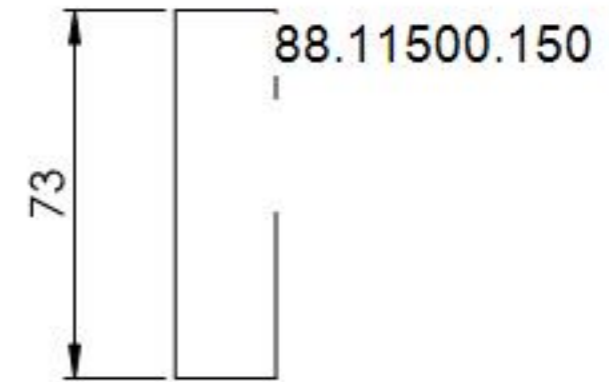
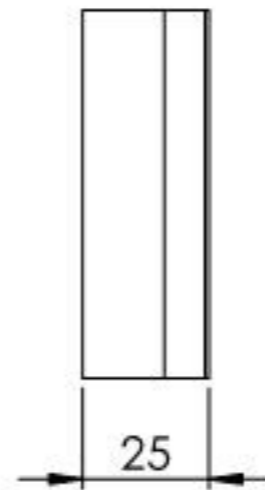
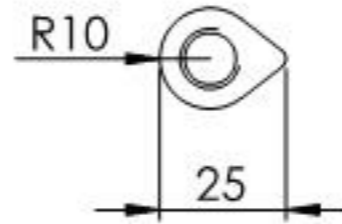
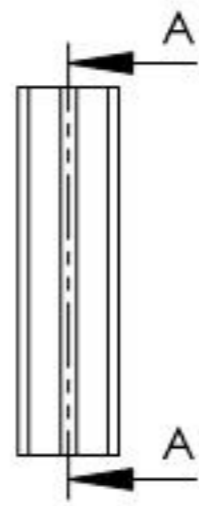
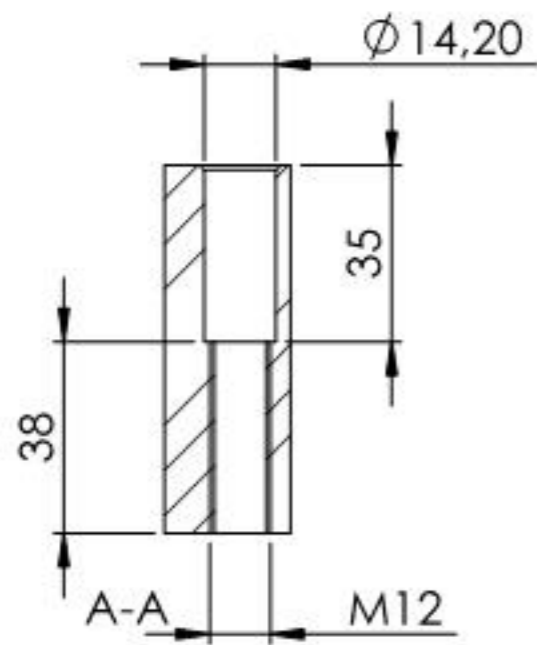

Name	Signatur	Datum	Artikelnummer	Oberfläche: Roh
Ch. Höfig	CH	21.11.2016	500-150 Teil1	
Werkstoff:		Hersteller		Blattformat
1.0037 (S235JR)				A4
Gewicht 0.132 kg		Maßstab: 1:2	Blatt 2 von 6	

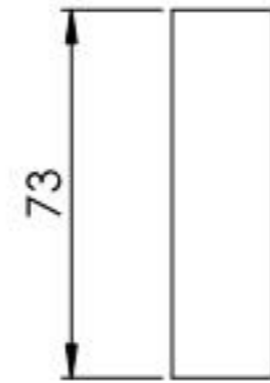
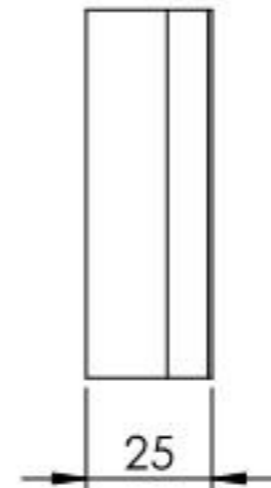
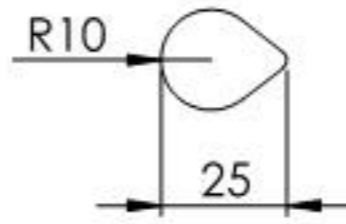
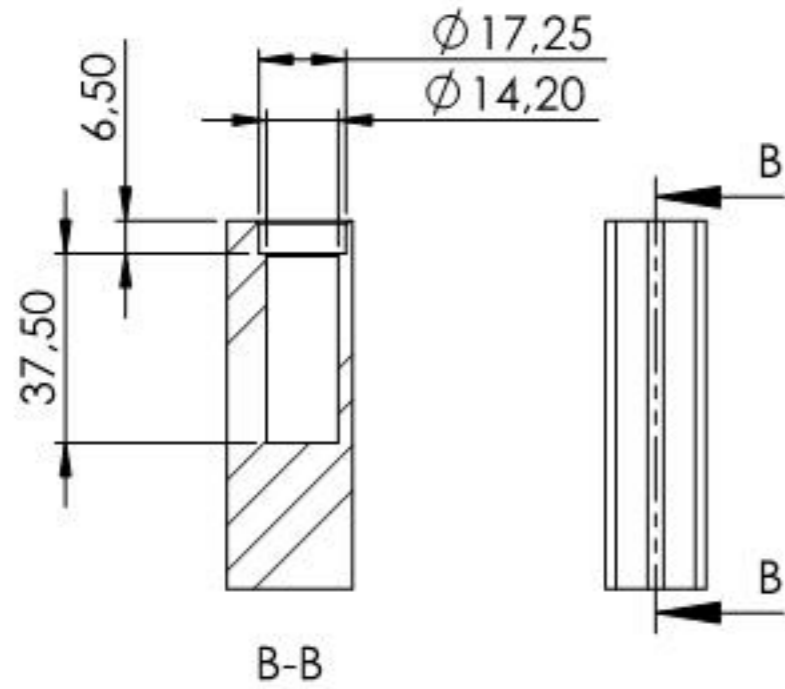

88.11500.150



Name	Signatur	Datum	Artikelnummer	Oberfläche: Roh
Ch. Höfig	CH	21.11.2016	500-150 Teil2	
Werkstoff:		Hersteller		Blattformat
1.0037 (S235JR)				A4
Gewicht 0,141 kg		Maßstab: 1:2		Blatt 3 von 6