

Name	Signatur	Datum	Artikelnummer	Oberfläche: Roh
Ch. Höfig	CH	29.03.2021	288.11230.40.VA	
Werkstoff:			Blattformat	
1.4301 (X5CrNi18-10)			A4	
Gewicht 0,281 kg		Maßstab: 1:2	Version: 1	Blatt 1 von 4

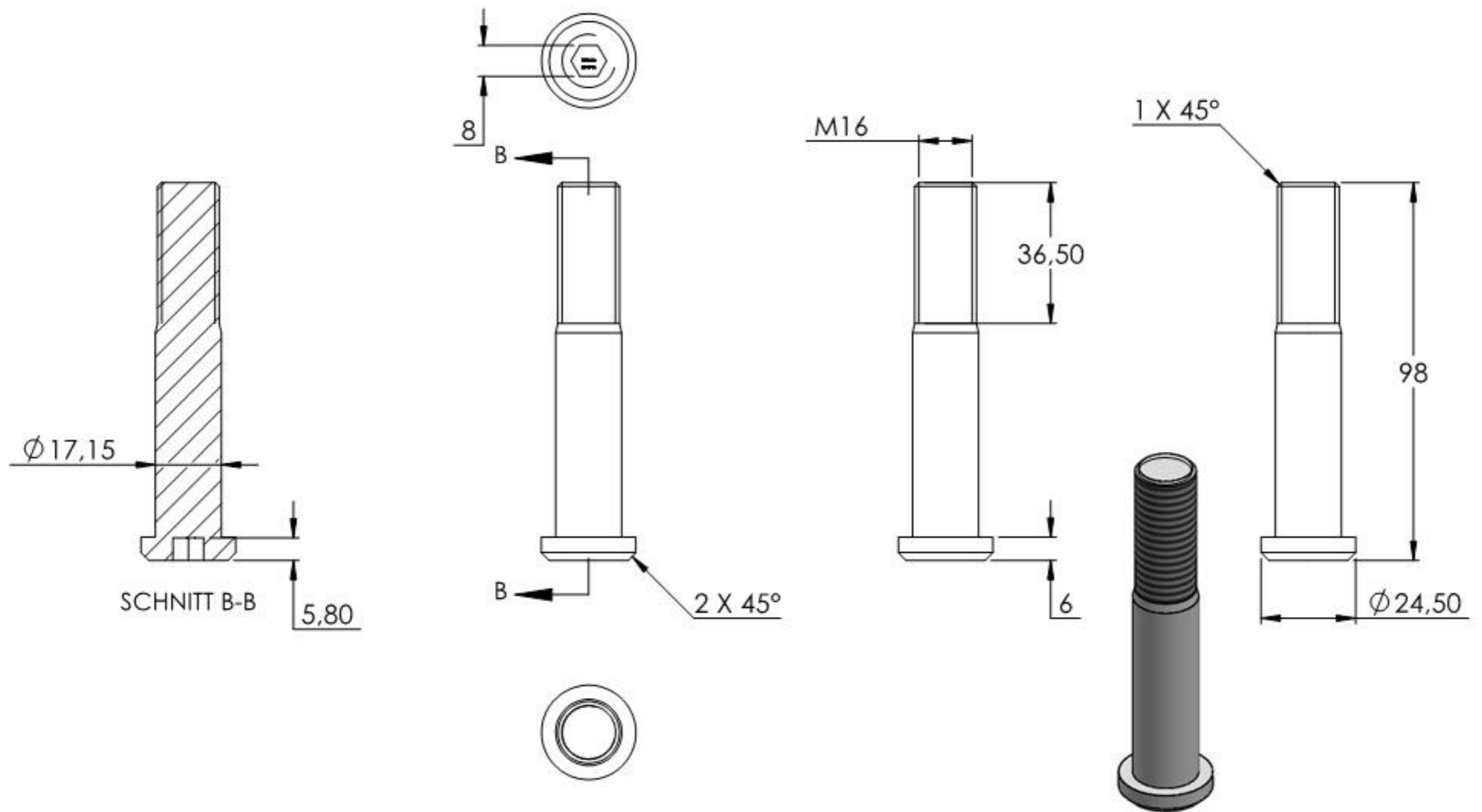

Name	Signatur	Datum	Artikelnummer	Oberfläche: Roh
Ch. Höfig	CH	29.03.2021	288.11230.40.VA	
Werkstoff:			Blattformat	
1.4301 (X5CrNi18-10)			A4	
Gewicht 0.177 kg		Massstab: 1:1.5	Version: 1	Blatt 2 von 4

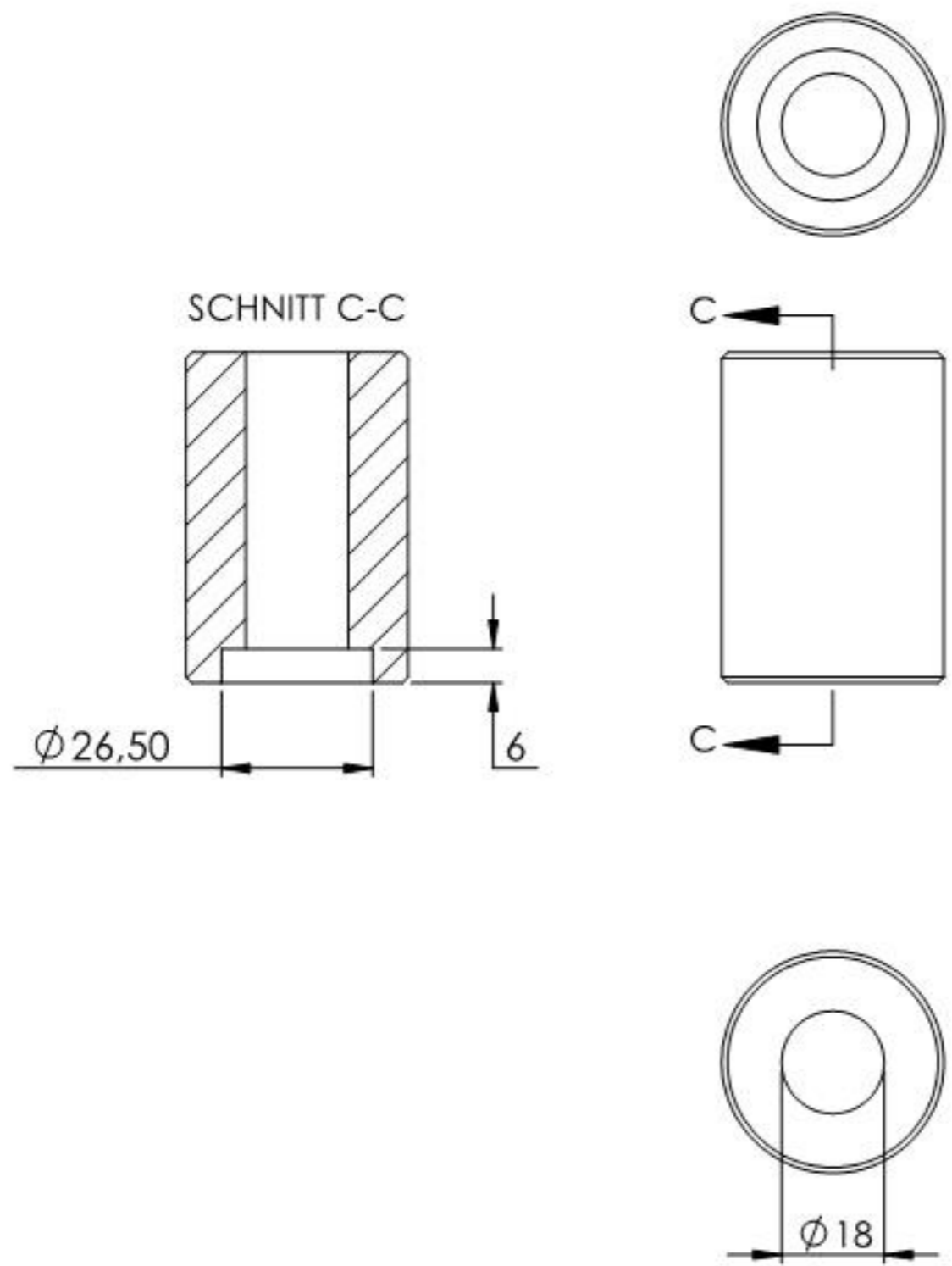

1 X 45°

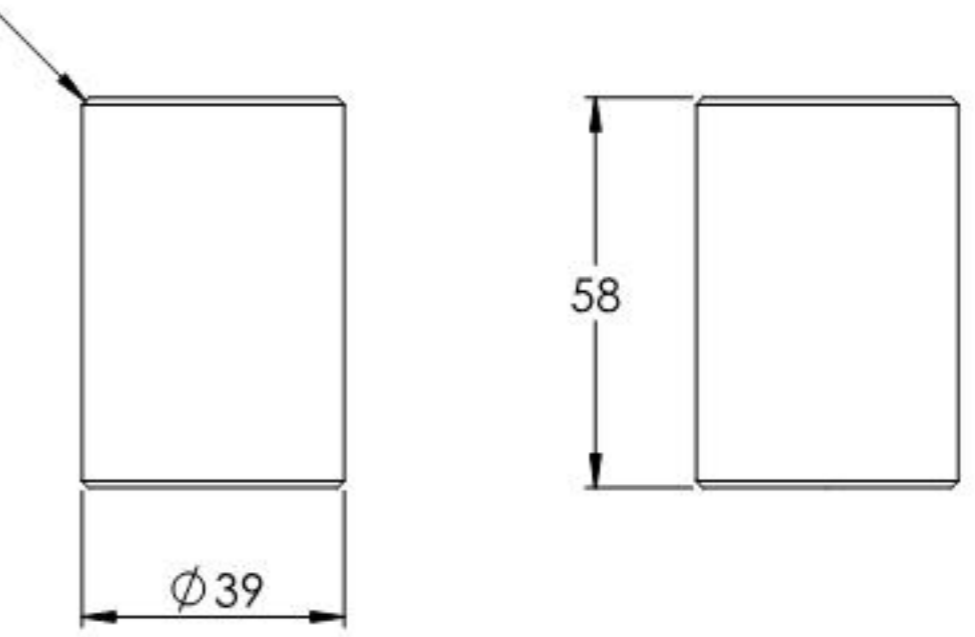

Name	Signatur	Datum	Artikelnummer	Oberfläche: Roh
Ch. Höfig	CH	29.03.2021	288.11230.40.VA	
Werkstoff:			Blattformat	
Nylon			A4	
Gewicht 0,061 kg		Maßstab: 1:1,5	Version: 1	Blatt 3 von 4