

Name	Signatur	Datum	Artikelnummer	Oberfläche: Roh
Ch. Höfig	CH	29.03.2021	230-30-VA	
Werkstoff:		Hersteller		Blattformat
1.4301 (X5CrNi18-10)				A4
Gewicht 0.197 kg		Maßstab: 1:2	Version: 1	Blatt 1 von 4

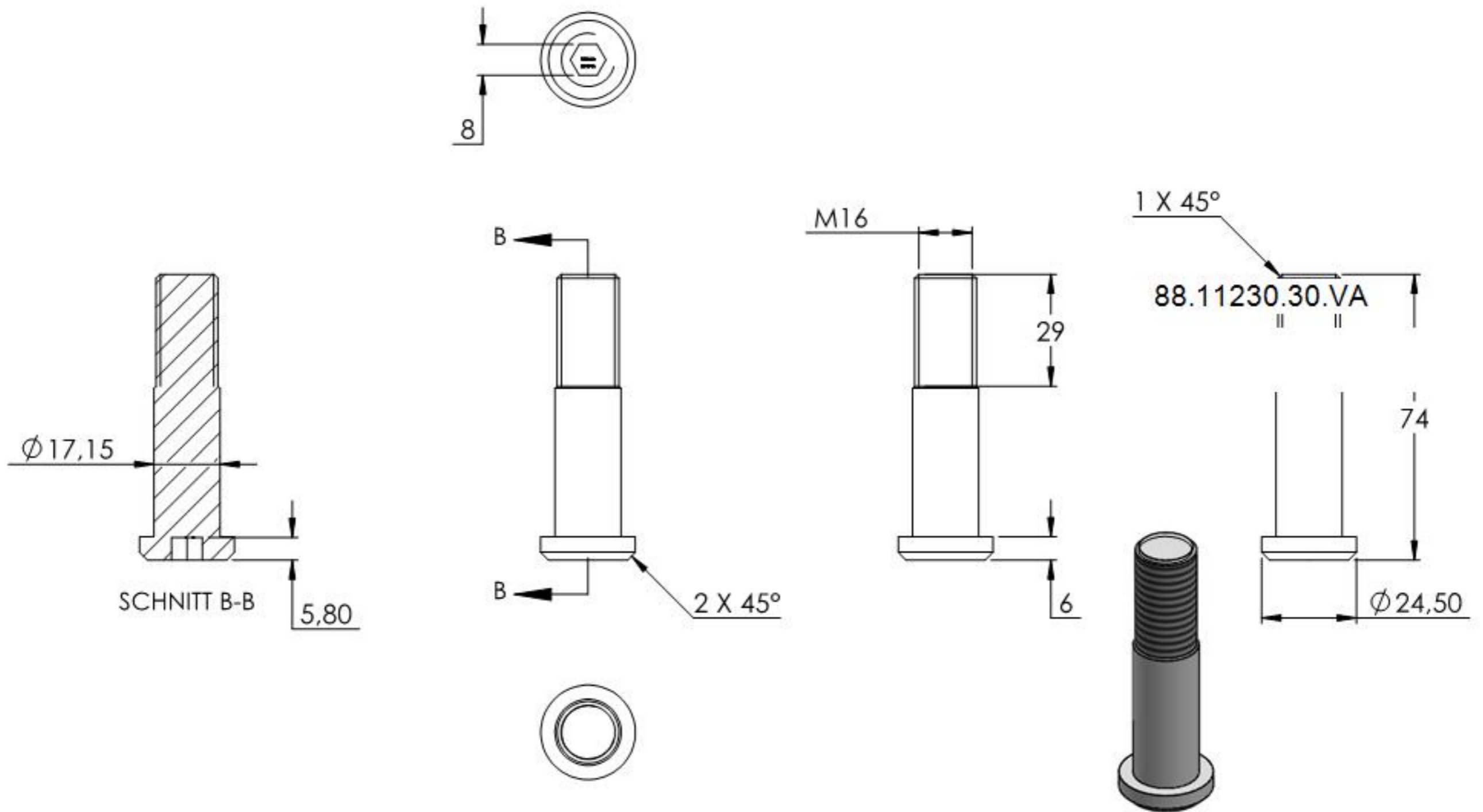

Name	Signatur	Datum	Artikelnummer	Oberfläche: Roh
Ch. Höfig	CH	29.03.2021	230-30-VA Teil1	
Werkstoff:		Hersteller		Blattformat
1.4301 (X5CrNi18-10)		 Feldmann <small>EDLSTAHL-ALUMINIUM-SCHWEIßEISEN</small>		A4
Gewicht 0.136 kg		Maßstab: 1:1.5	Version: 1	Blatt 2 von 4



SCHNITT C-C

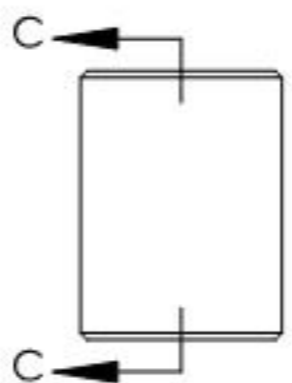
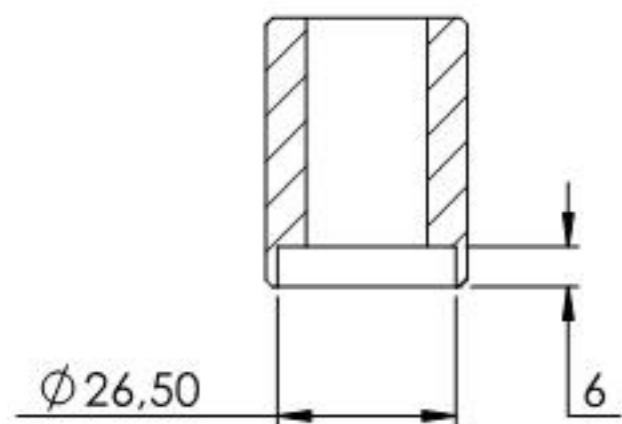

1 X 45°

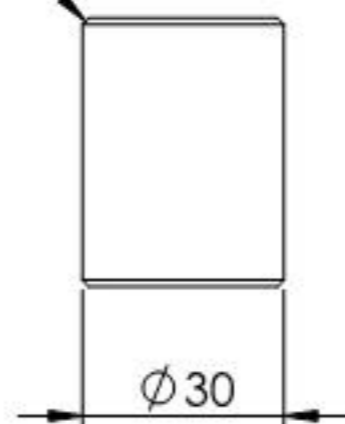

88.11230.30.VA

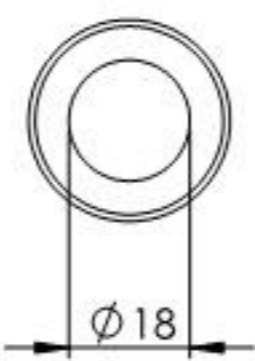

Name	Signatur	Datum	Artikelnummer	Oberfläche: Roh
Ch. Höfig	CH	29.03.2021	230-30-VA Teil2	
Werkstoff: Nylon		Hersteller 		Blattformat A4
Gewicht 0.019 kg		Maßstab: 1:1.5	Version: 1	Blatt 3 von 4