

Name	Signatur	Datum	Artikelnummer	Oberfläche: Eloxierf
Ch. Höfig	CH	16.02.2021	188.11180.57.S	
Werkstoff:				Blattformat
Aluminium [EN AW6060 / 3.3206]				A4
Gewicht 0.342 kg		Maßstab: 1:2	Version: 1	Blatt 1 von 4

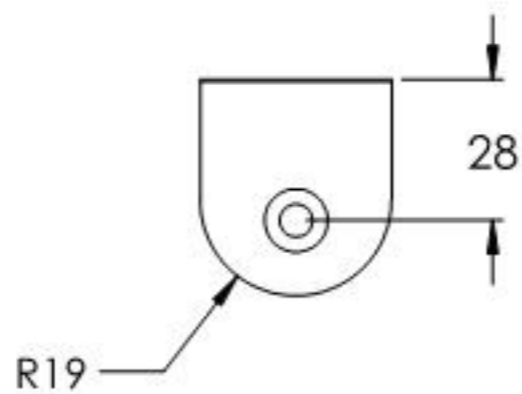

Name	Signatur	Datum	Artikelnummer	Oberfläche: Eloxierf
Ch. Höfig	CH	16.02.2021	188.11180.57.S	
Werkstoff:				Blattformat
Aluminium [EN AW6060 / 3.3206]				A4
Gewicht 0,078 kg		Massstab: 1:2	Version: 1	Blatt 2 von 4

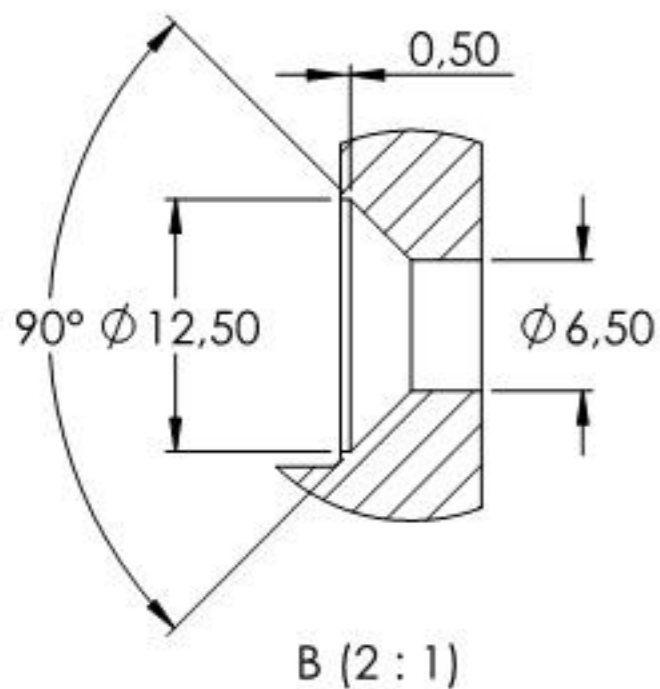
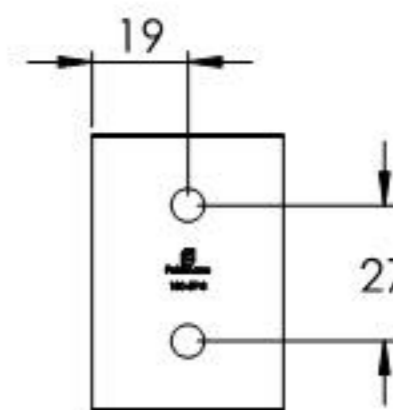
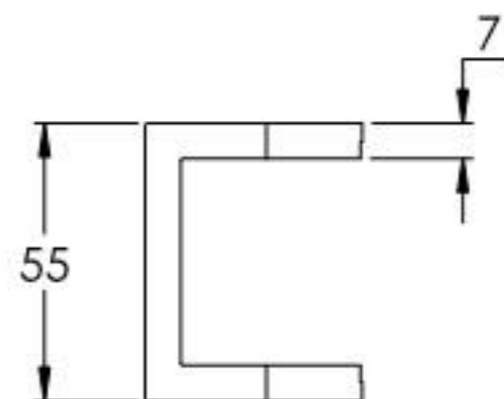
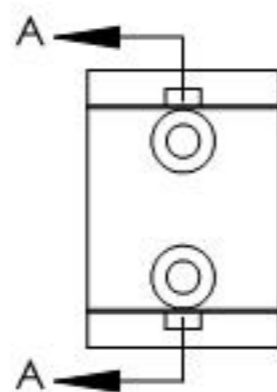
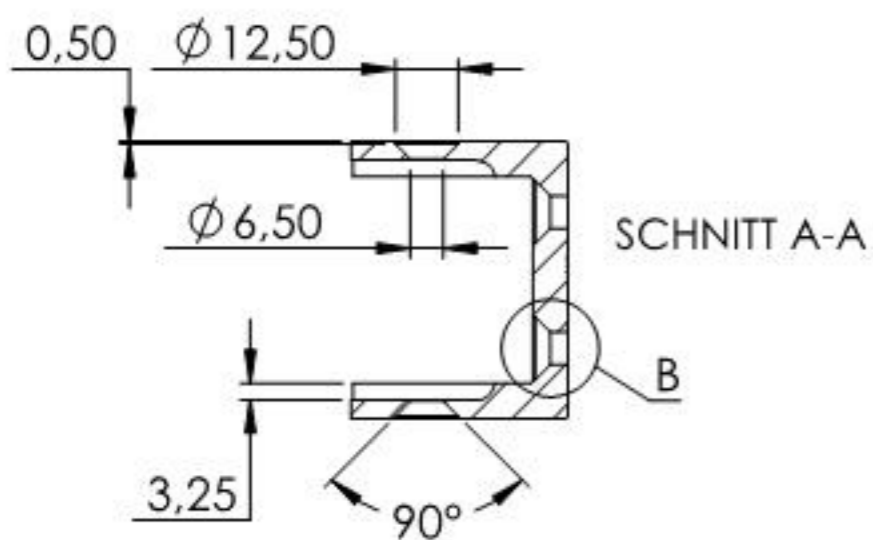
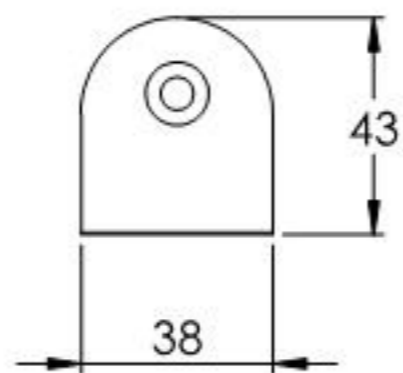
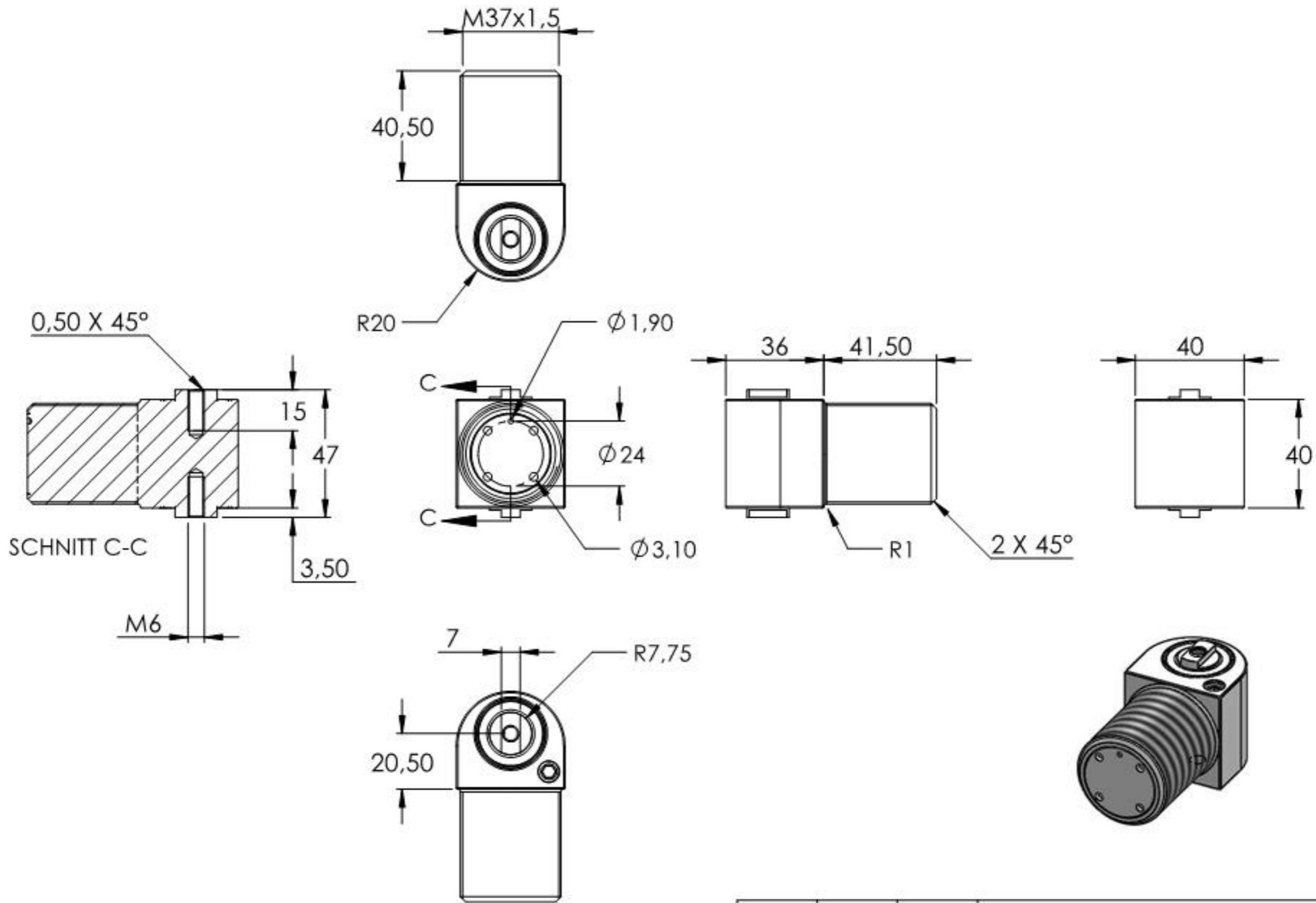

Name	Signatur	Datum	Artikelnummer	Oberfläche: Eloxierf
Ch. Höfig	CH	16.02.2021	188.11180.57.S	
Werkstoff:				Blattformat
Aluminium [EN AW6060 / 3.3206]				A4
Gewicht 0.256 kg		Maßstab: 1:2	Version: 1	Blatt 3 von 4