

Name	Signatur	Datum	Artikelnummer	Oberfläche: Geschliffen Korn 240
Ch. Höfig	CH	20.02.2020	56159-320V	
Werkstoff:				Blattformat
1.4301 (X5CrNi18-10)				A4
Gewicht 0.657 kg		Maßstab: 1:2	Version: 1	Blatt 1 von 4

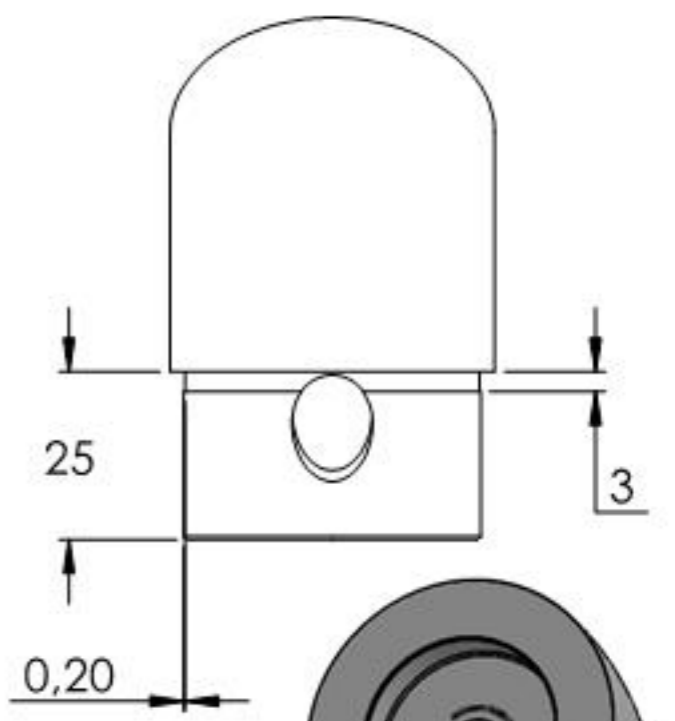

Name	Signatur	Datum	Artikelnummer	Oberfläche: Geschliffen Korn 240
Ch. Höfig	CH	20.02.2020	56159-320V Teil1	
Werkstoff:				Blattformat
1.4301 (X5CrNi18-10)				A4
Gewicht 0.284 kg		Maßstab: 1:1.5	Version: 1	Blatt 2 von 4

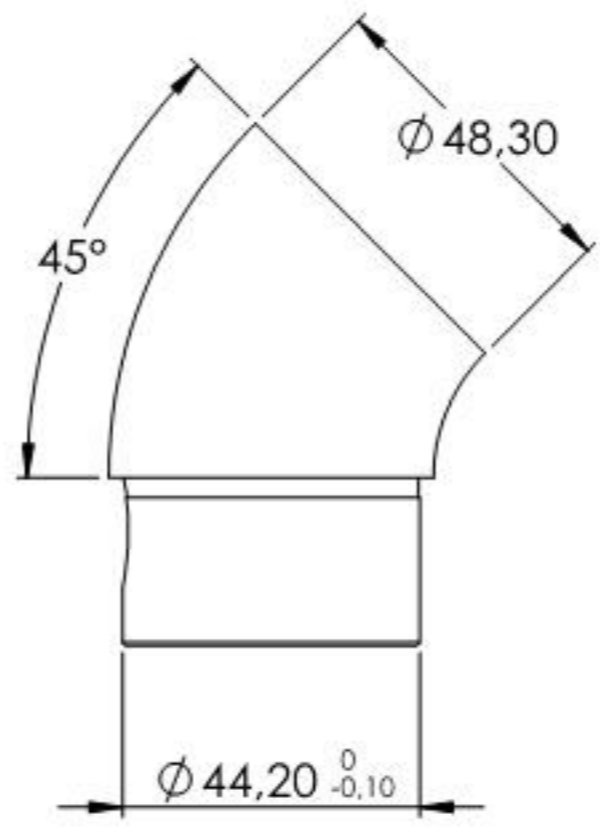
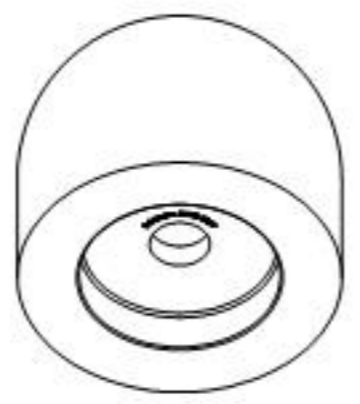
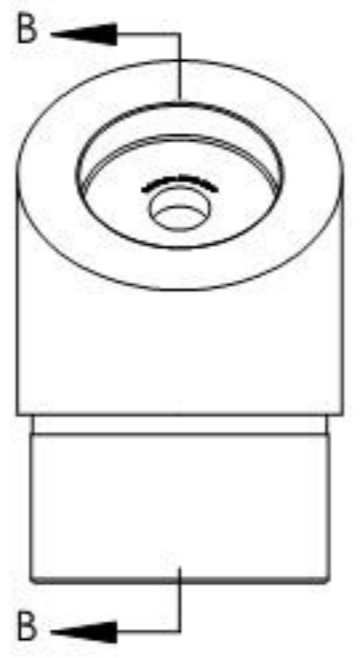
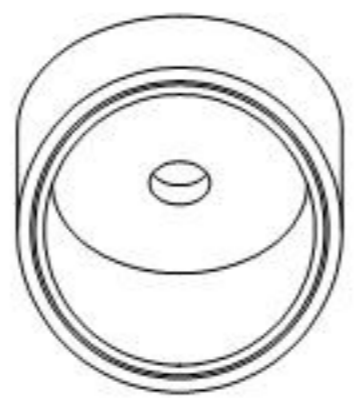
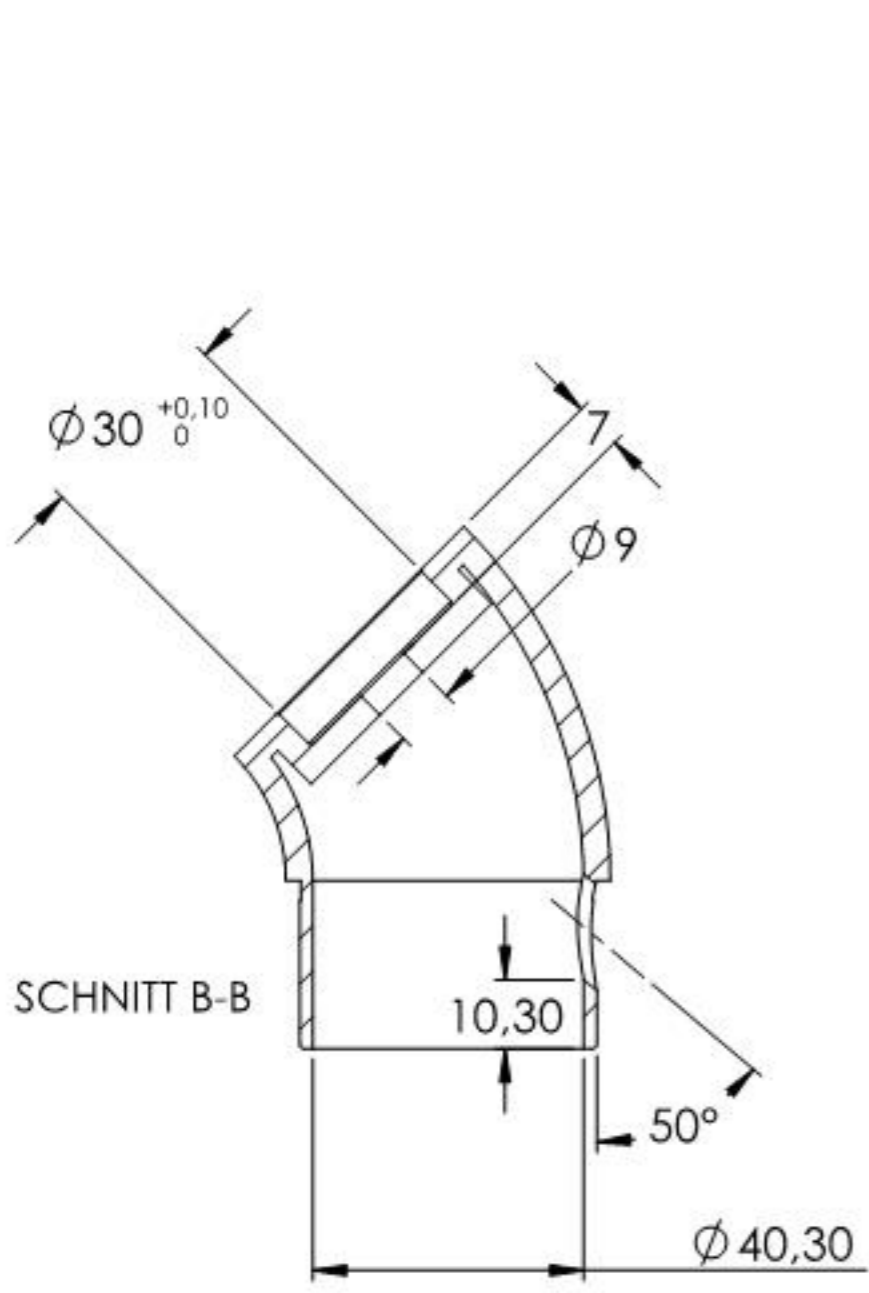
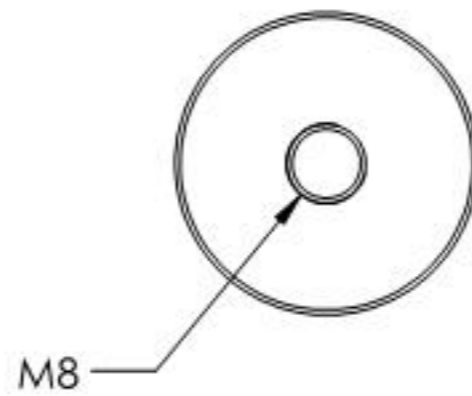
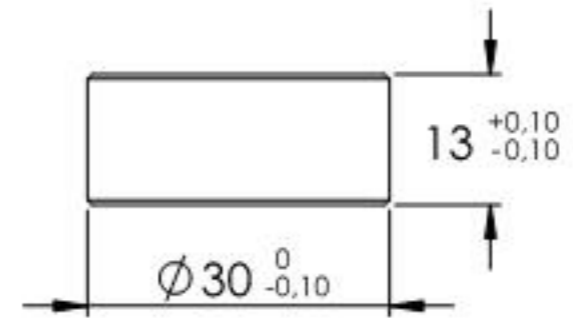
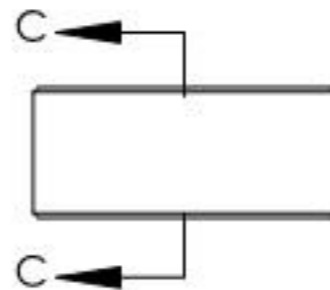
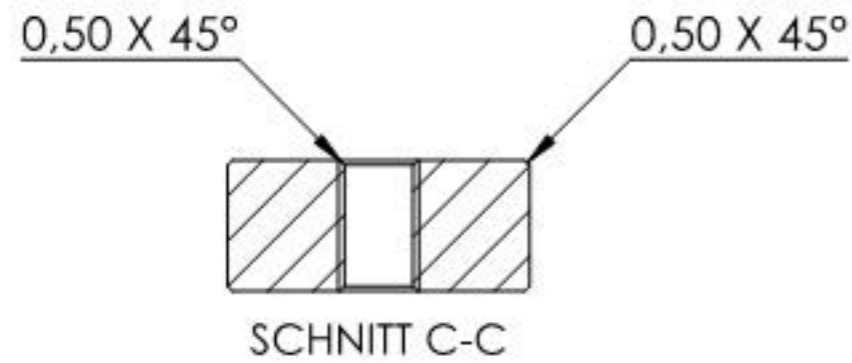
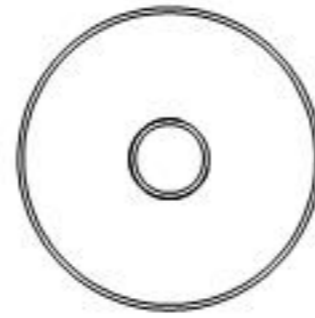

Name	Signatur	Datum	Artikelnummer	Oberfläche: Roh
Ch. Höfig	CH	20.02.2020	56159-320V Teil2	
Werkstoff: 1.4301 (X5CrNi18-10)				Blattformat A4
Gewicht 0.069 kg	Maßstab: 1:1	Version: 1	Blatt 3 von 4	