

G (1.5 : 1)

SCHNITT B-B

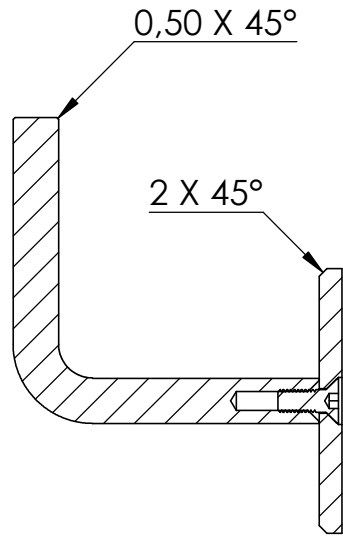

SCHNITT A-A

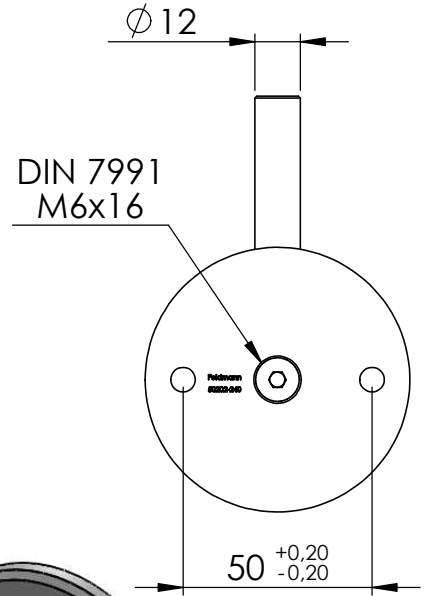
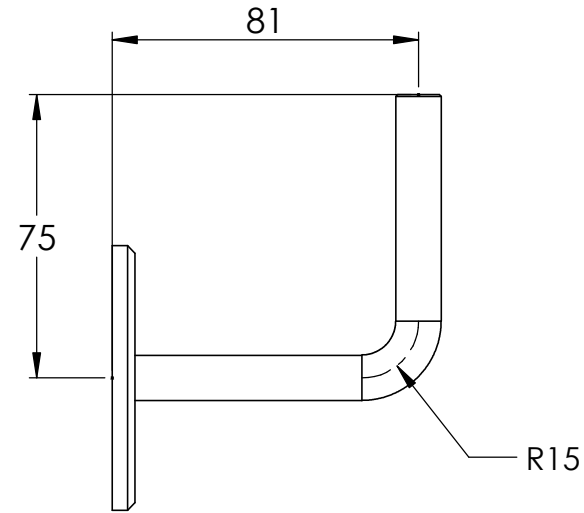
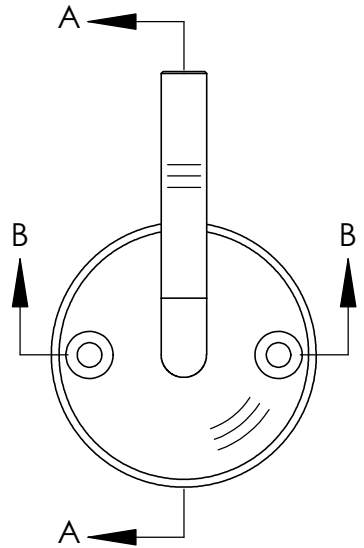