

SCHNITT A-A

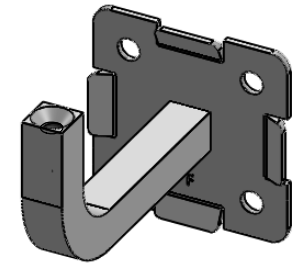

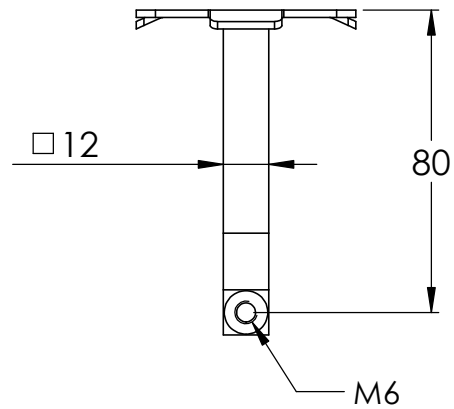

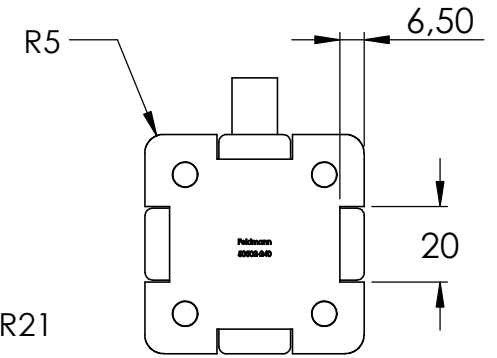
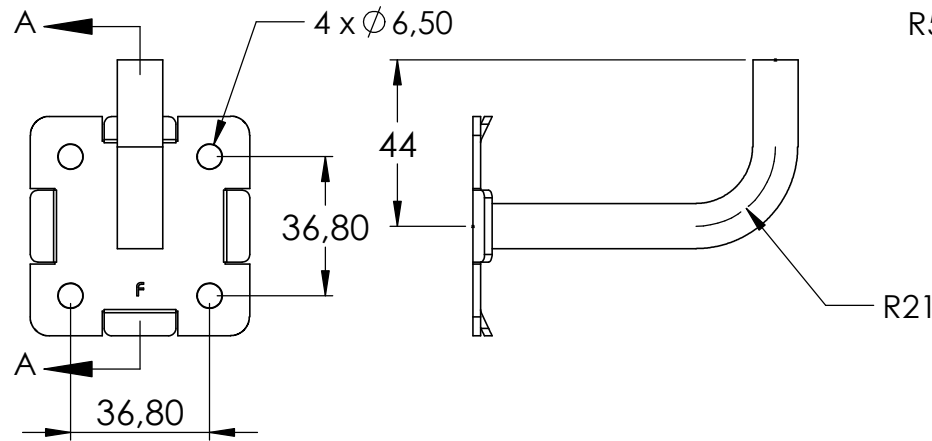
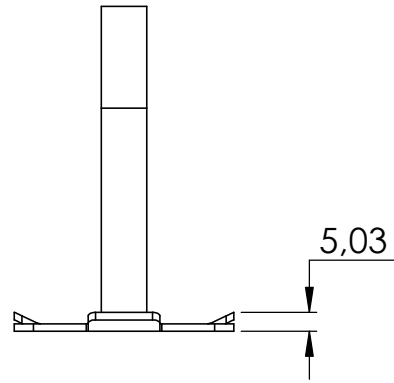
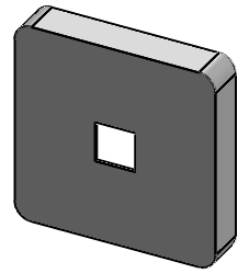
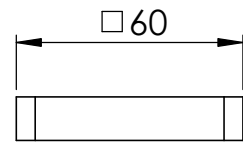
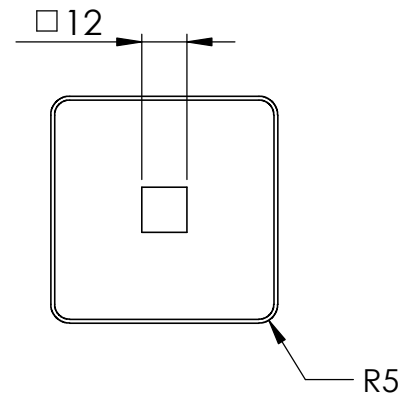
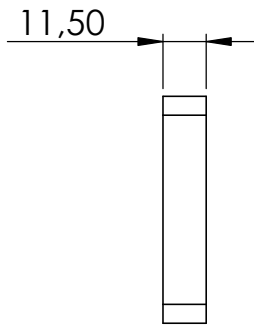
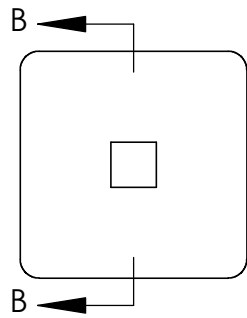
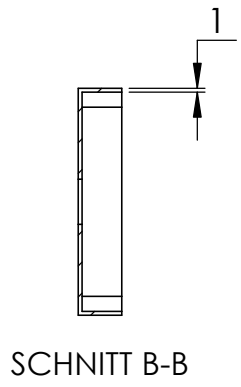
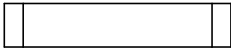
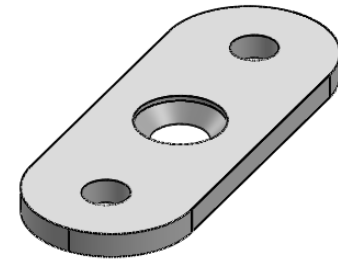
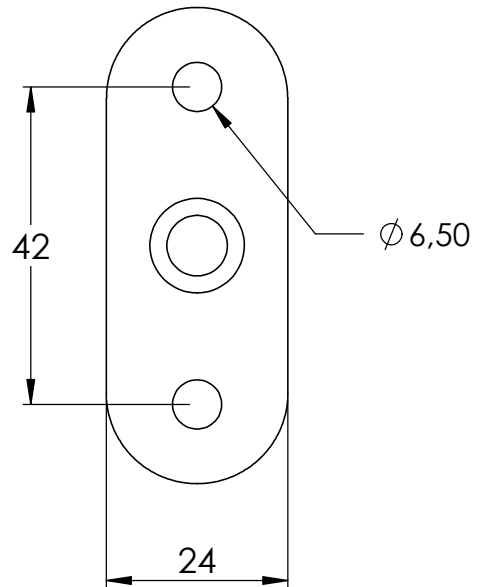
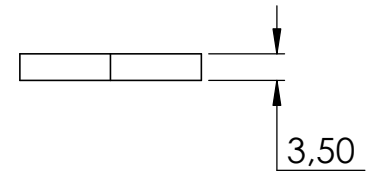
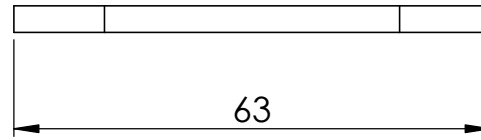
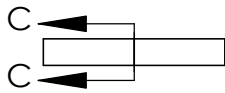
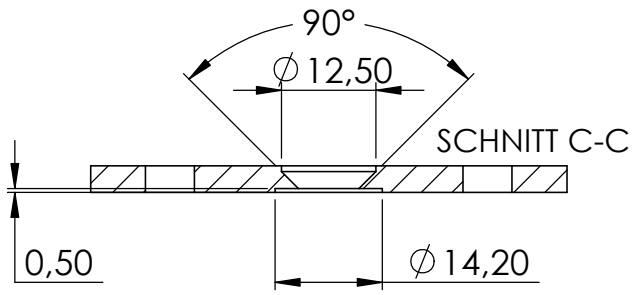
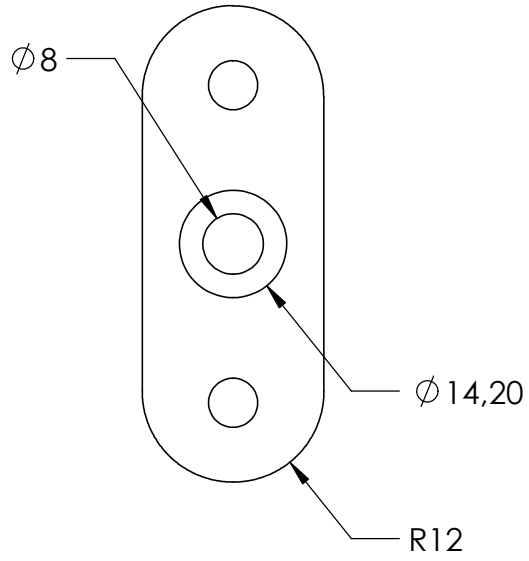

4

DIN 7991 - M6 x 16 ---
9.7S

1

