

Name	Signatur	Datum	Artikelnummer	Oberfläche: Geschliffen Korn 240
Ch. Höfig	CH	17.09.2020	ξ11.2035.4	
Werkstoff:				Blattformat
1.4301 (X5CrNi18-10)				A4
Gewicht 0.337 kg		Maßstab: 1:2.5	Version: 1	Blatt 1 von 7

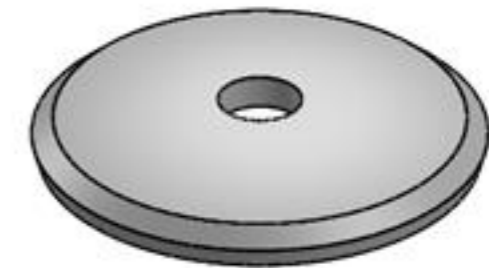

Name	Signatur	Datum	Artikelnummer	Oberfläche: Geschliffen Korn 240
Ch. Höfig	CH	17.09.2020	ξ 11.2035.4 ₁₁	
Werkstoff:				Blattformat
1.4301 (X5CrNi18-10)				A4
Gewicht 0.134 kg		Maßstab: 1:1.5	Version: 1	Blatt 2 von 7

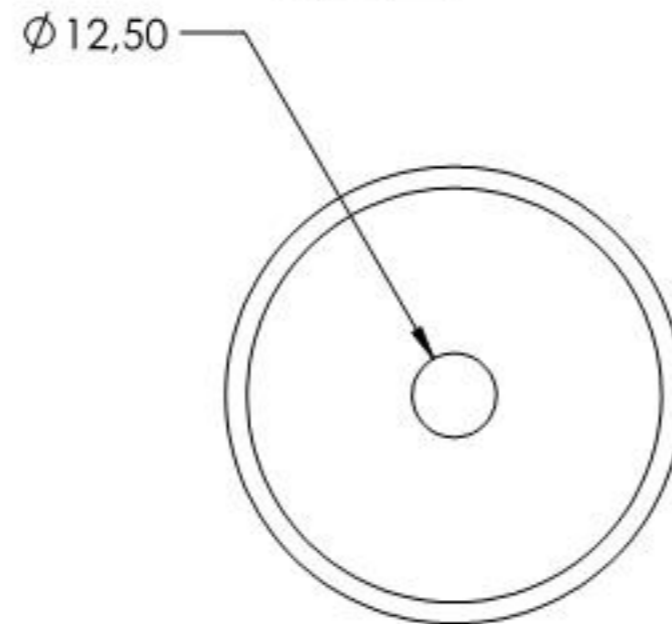
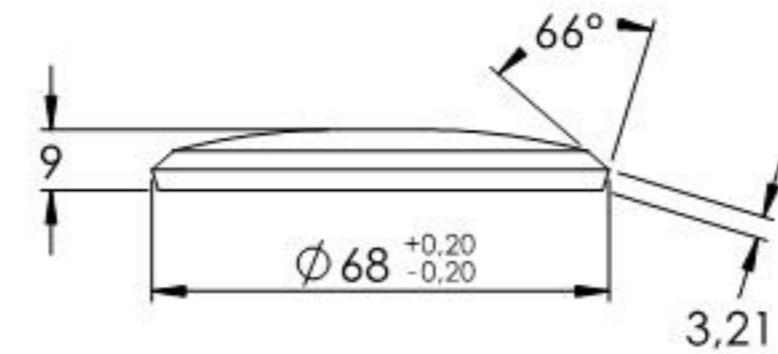
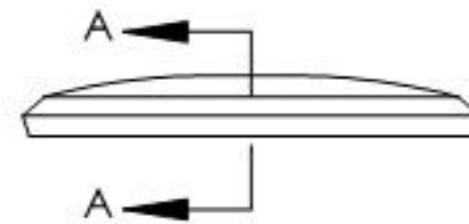
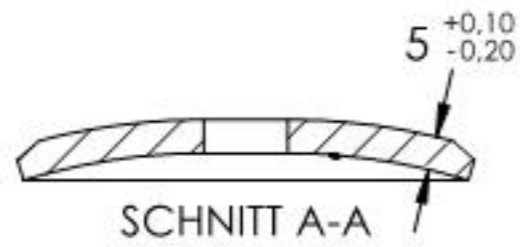
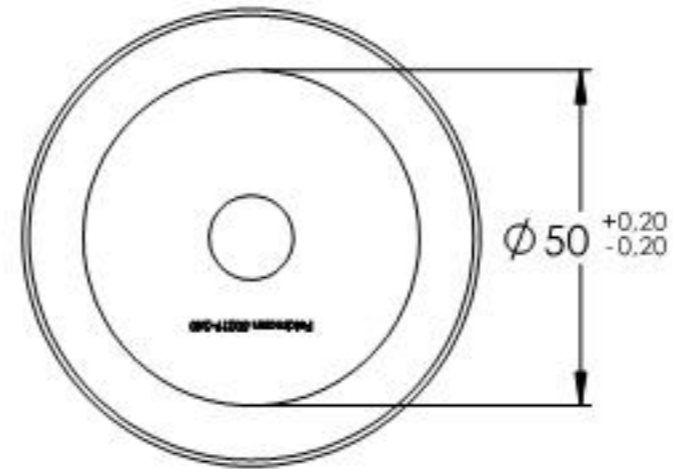
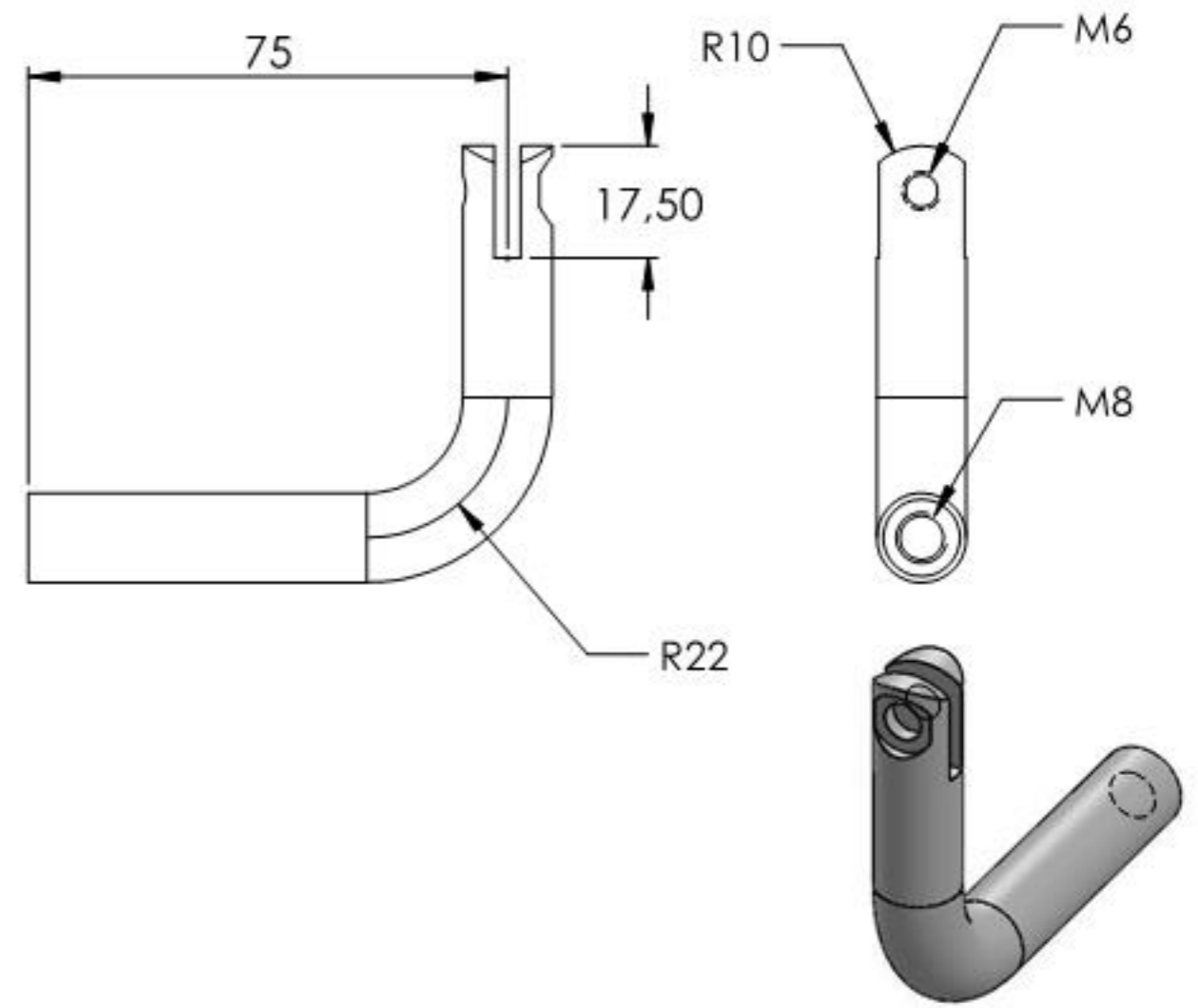
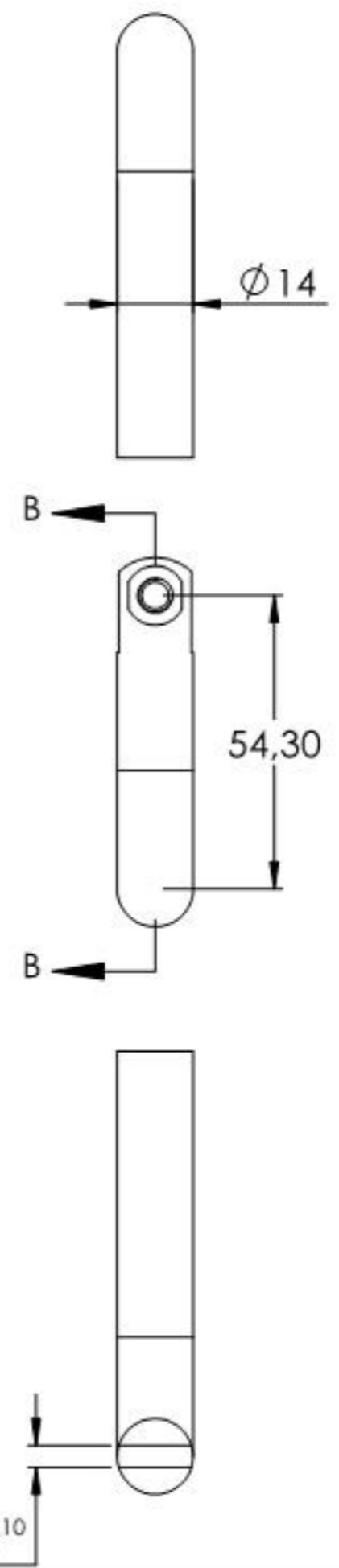
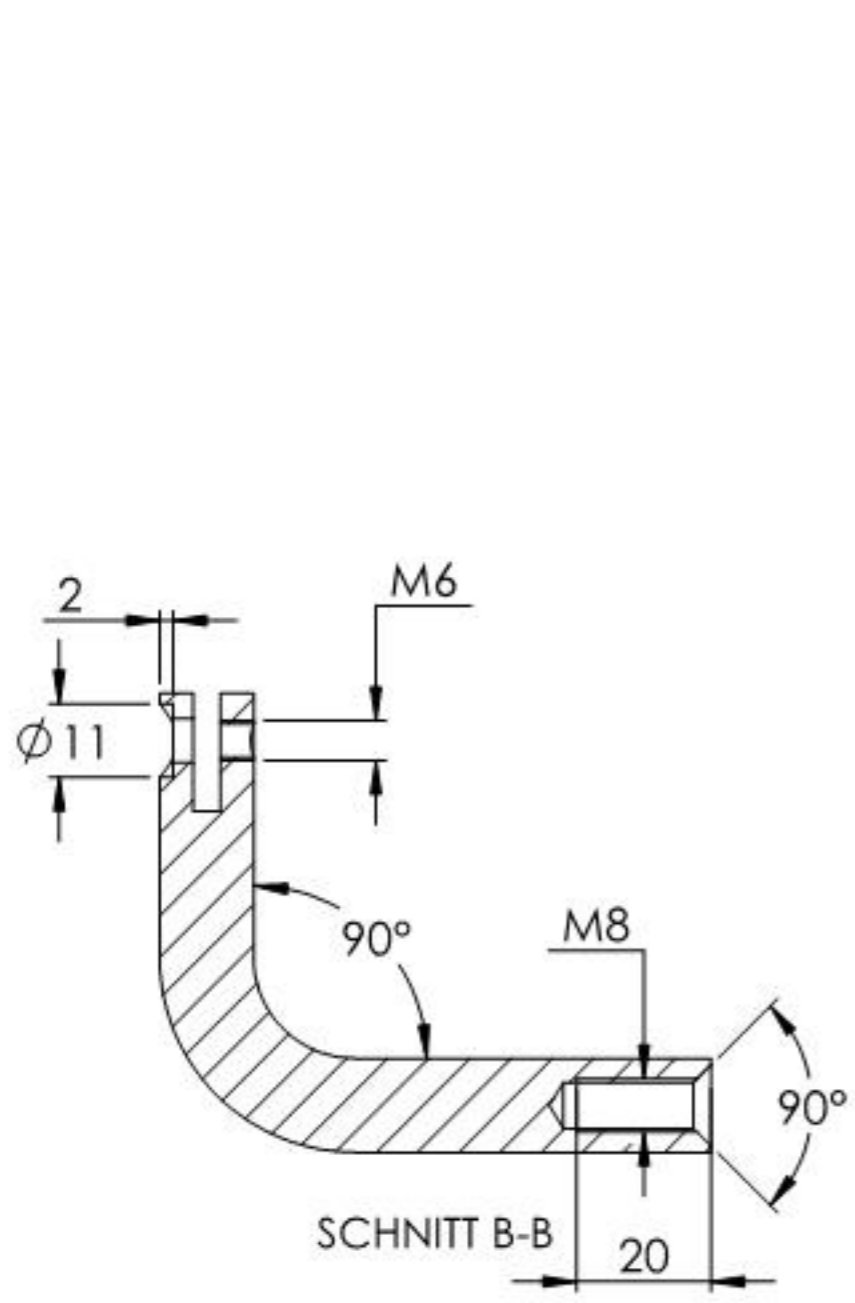

Name	Signatur	Datum	Artikelnummer	Oberfläche: Geschliffen Korn 240
Ch. Höfig	CH	17.09.2020	ξ 11.2035.4 12	
Werkstoff:				Blattformat
1.4301 (X5CrNi18-10)				A4
Gewicht 0.136 kg		Massstab: 1:1.5	Version: 1	Blatt 3 von 7