

Name	Signatur	Datum	Artikelnummer	Oberfläche: Geschliffen Korn 240
Ch. Höfig	CH	07.10.2020	ξ11.1662.4	
Werkstoff:				Blattformat
1.4301 (X5CrNi18-10)				A4
Gewicht 0.096 kg		Massstab: 1:1	Version: 1	Blatt 1 von 4

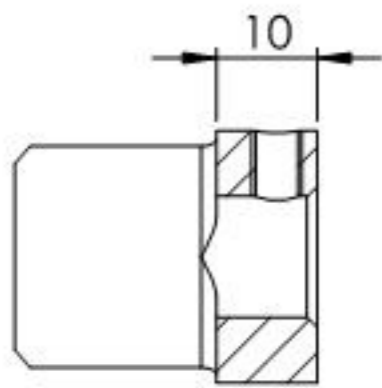

SCHNITT B-B

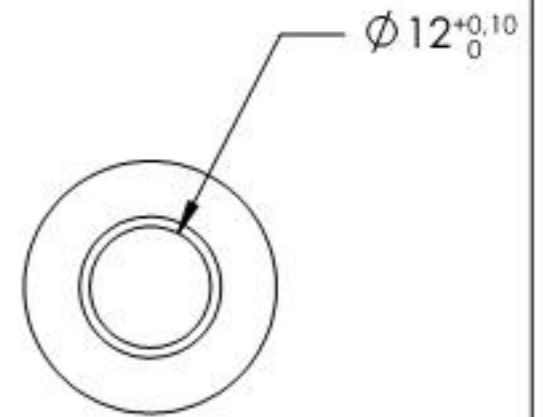
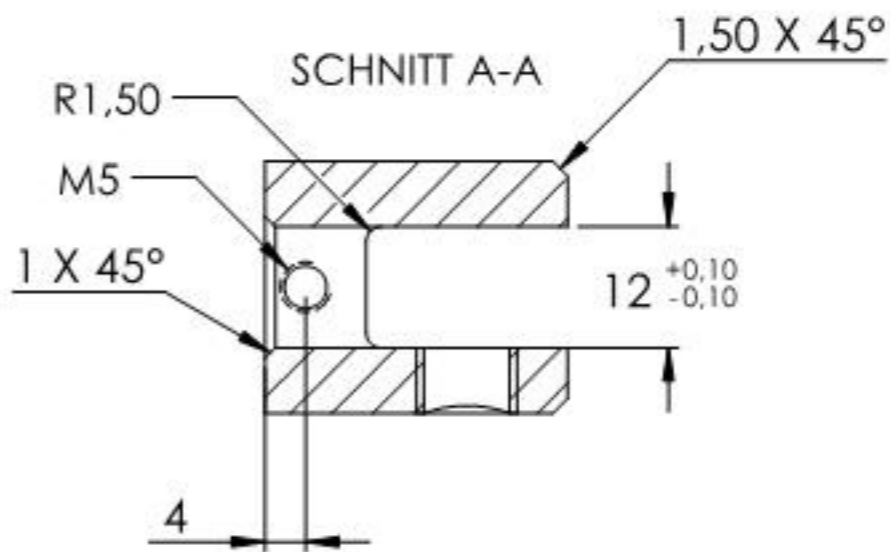
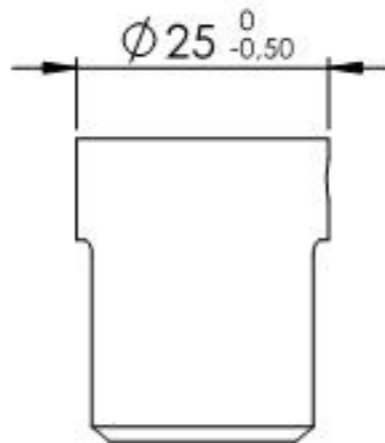
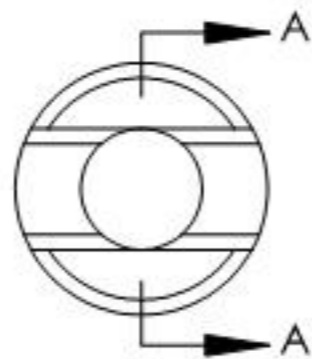
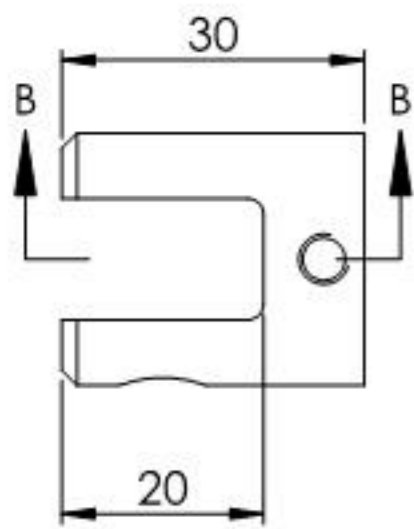
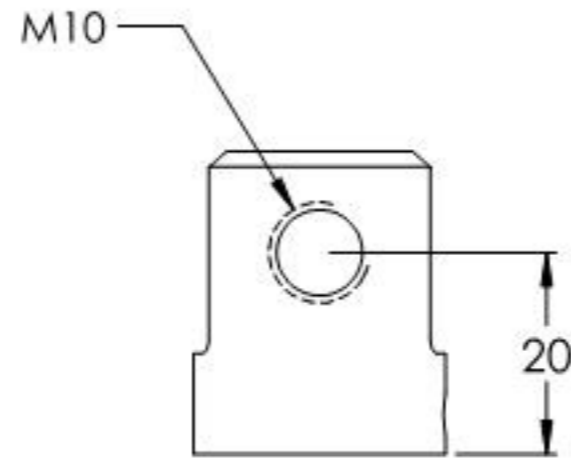

Name	Signatur	Datum	Artikelnummer	Oberfläche: Geschliffen Korn 240
Ch. Höfig	CH	07.10.2020	ξ11.1662.4j11	
Werkstoff:				Blattformat
1.4301 (X5CrNi18-10)				A4
Gewicht 0,058 kg		Massstab: 1:1	Version: 1	Blatt 2 von 4

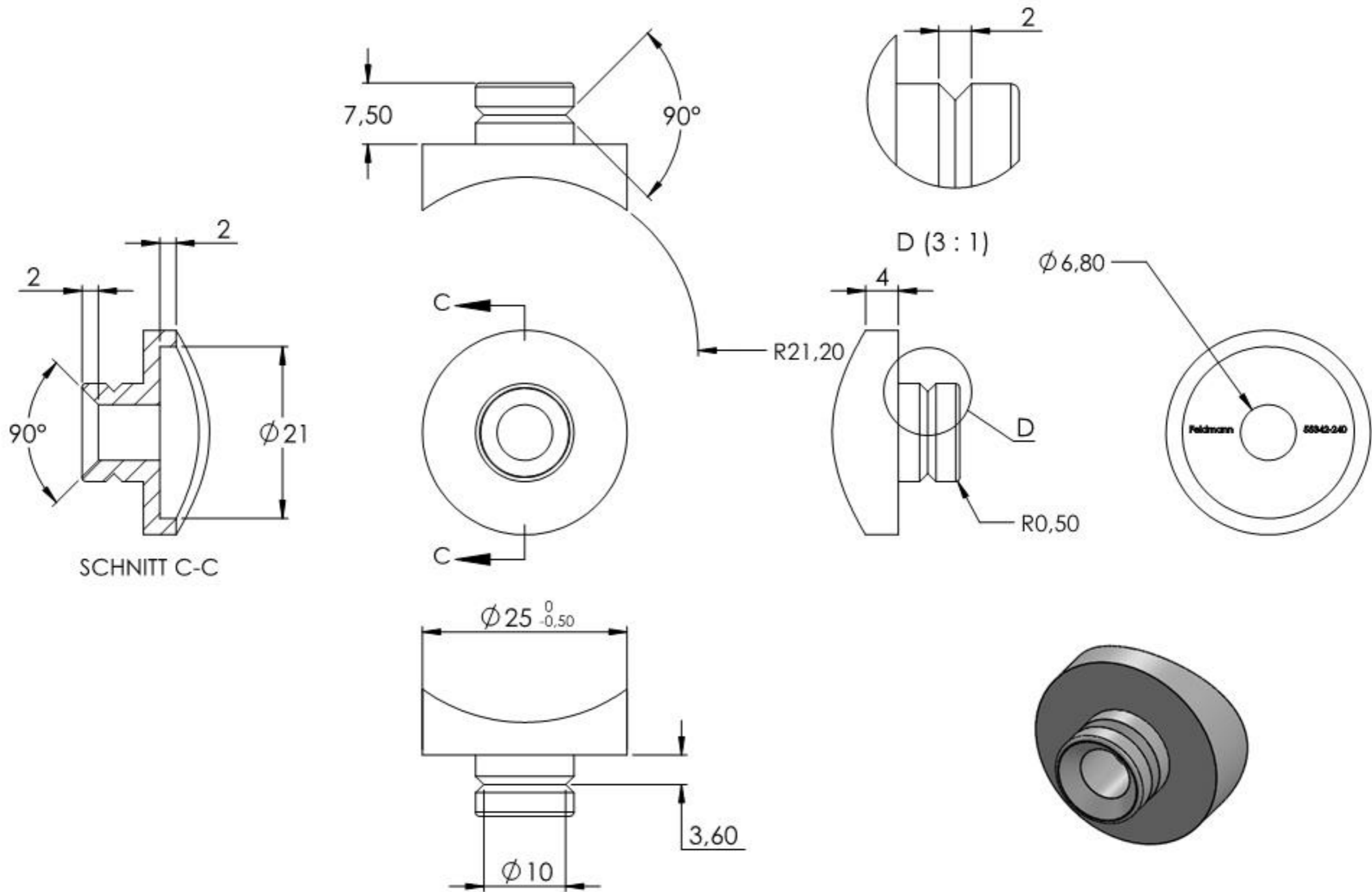

SCHNITT C-C

Name	Signatur	Datum	Artikelnummer	Oberfläche: Geschliffen Korn 240
Ch. Höfig	CH	07.10.2020	$\xi 11.1662.4_{j1}$	
Werkstoff:				Blattformat
1.4301 (X5CrNi18-10)				A4
Gewicht 0,015 kg		Maßstab: 1,5:1	Version: 1	Blatt 3 von 4