

11.1003.4

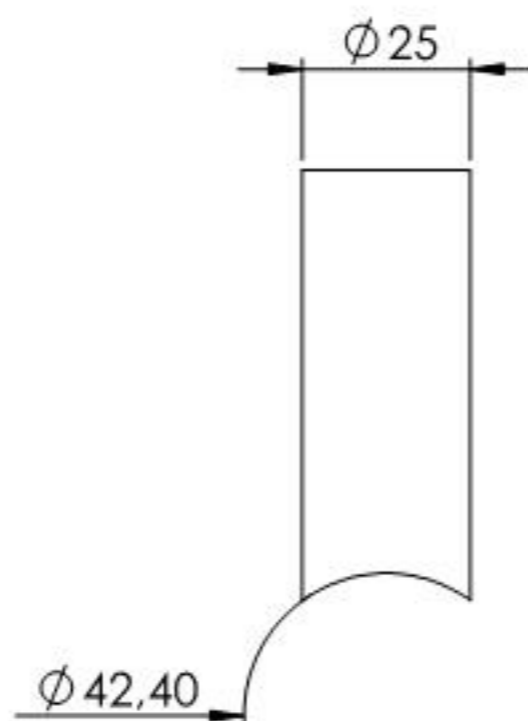

Name	Signatur	Datum	Artikelnummer	Oberfläche: Geschliffen Korn 240
Ch. Höfig	CH	05.06.2018	51180-240-42	
Werkstoff: 1.4301 (X5CrNi18-10)	Hersteller			Blattformat
Gewicht 0.168 kg	Maßstab: 1:1.5	Version: 1	Blatt 1 von 4	A4

11.1003.4

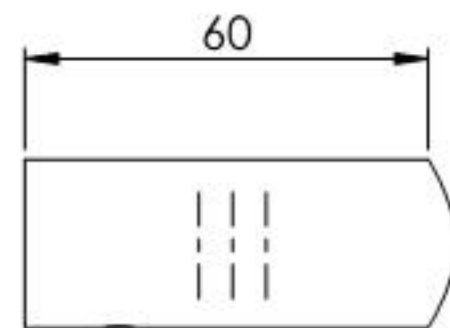
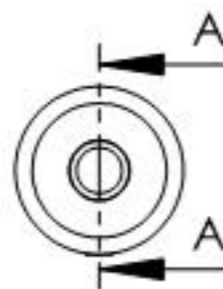
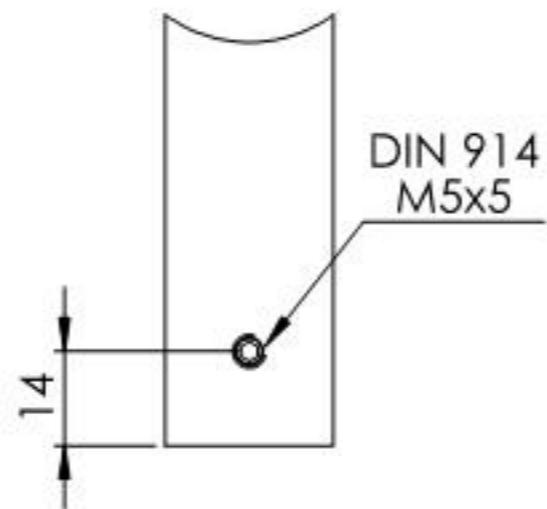
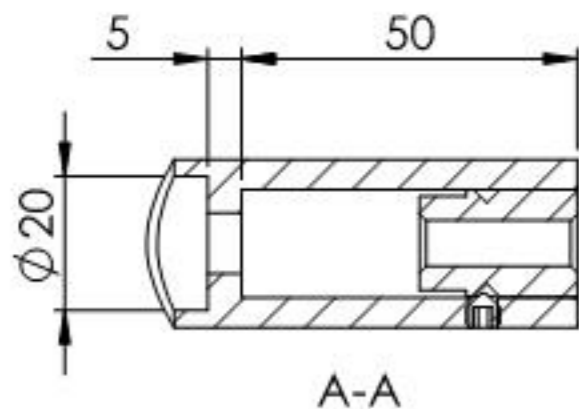
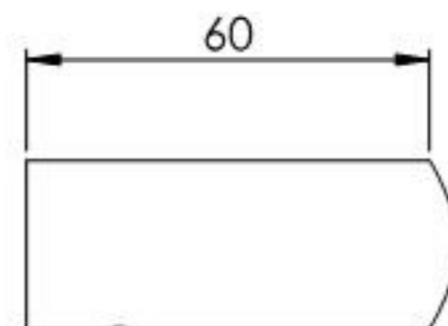
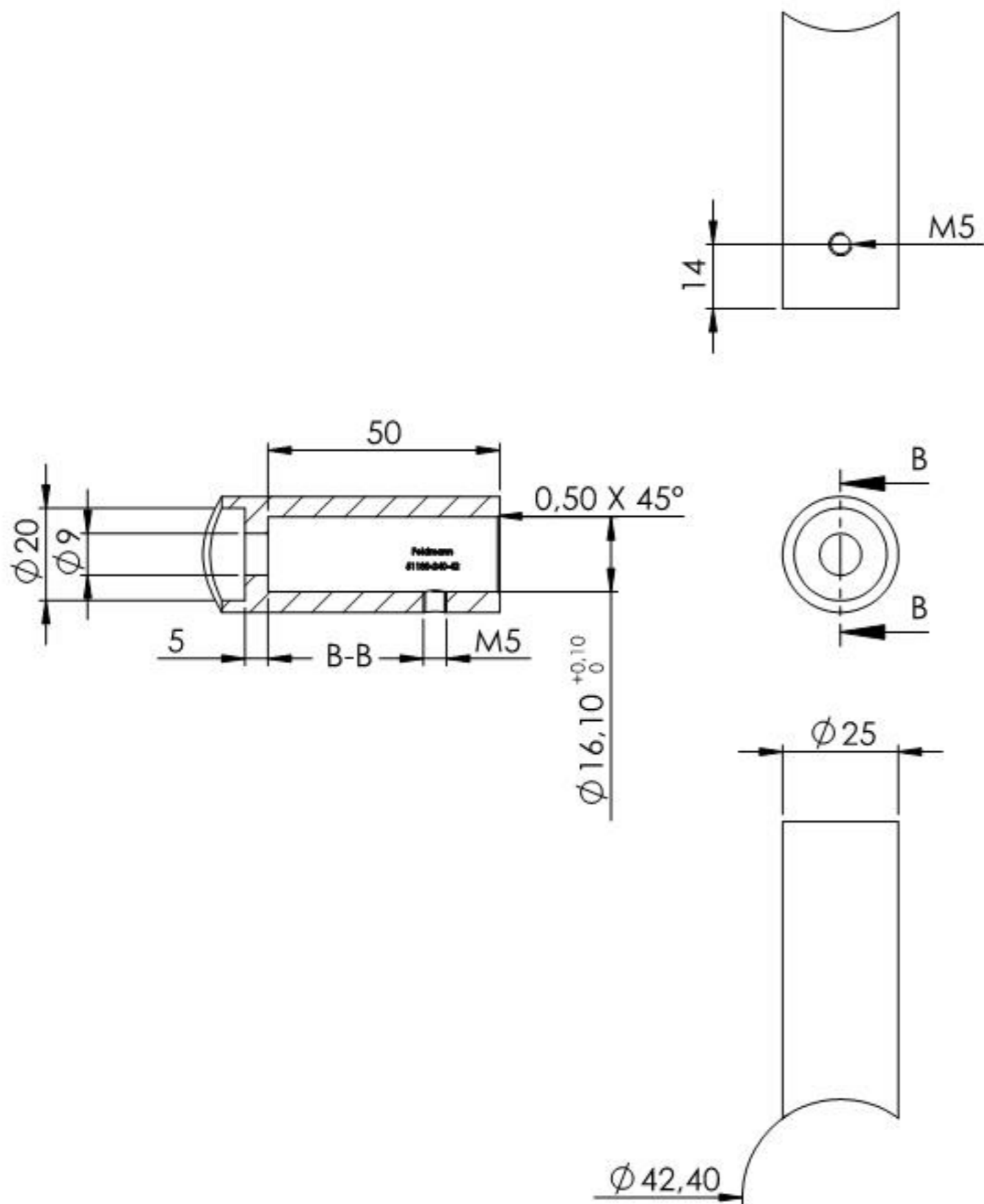

Name	Signatur	Datum	Artikelnummer	Oberfläche: Geschliffen Korn 240
Ch. Höfig	CH	05.06.2018	51180-240-42 Teil1	
Werkstoff:		Hersteller		Blattformat
1.4301 (X5CrNi18-10)				A4
Gewicht 0.139 kg		Maßstab: 1:1,5	Version: 1.1	Blatt 2 von 4

11.1003.4

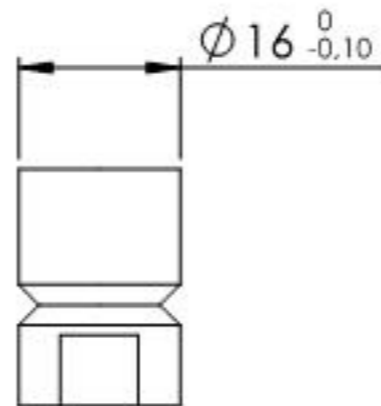
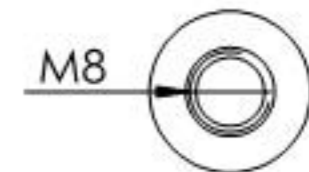
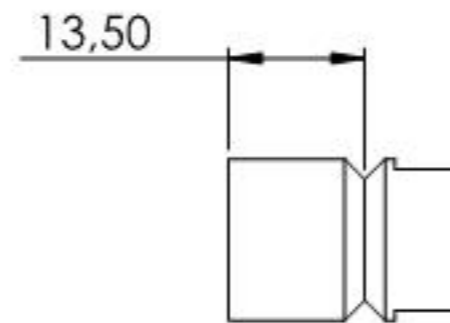
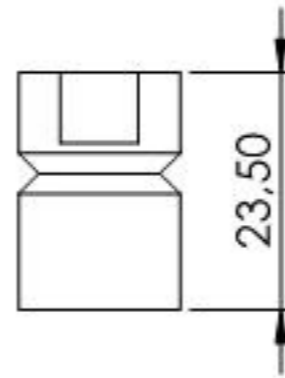
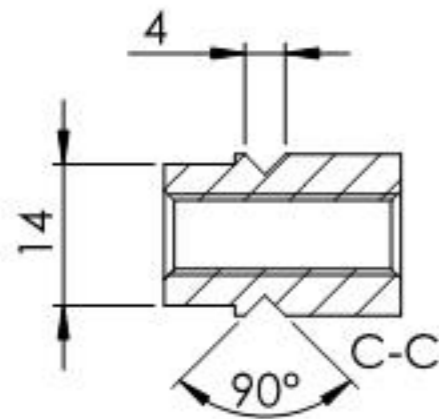

Name	Signatur	Datum	Artikelnummer	Oberfläche: Roh
Ch. Höfig	CH	05.06.2018	5x180-240-xx Teil2	
Werkstoff: 1.4301 (X5CrNi18-10)			Hersteller 	Blattformat A4
Gewicht 0,028 kg			Maßstab: 1:1	Version: 1
Blatt 3 von 4				

11.1003.4