

10.5100.0

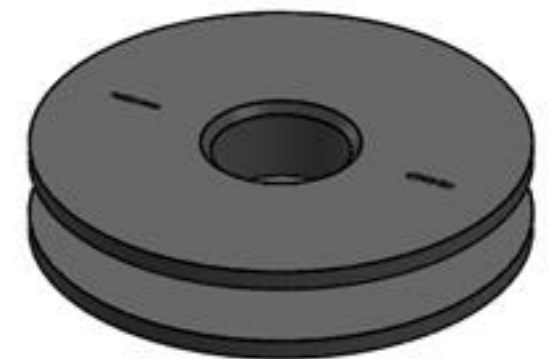

Name	Signatur	Datum	Artikelnummer	Oberfläche: Roh
Ch. Höfig	CH	30.10.2020	60195-GU	
Werkstoff: EPDM			Hersteller	Blattformat
			 <b>Feldmann</b> EDELSTAHL-ALUMINIUM-SCHWEIßEISEN	A4
Gewicht 0,009 kg			Maßstab: 1:1	Version: 1
Blatt 1 von 4				

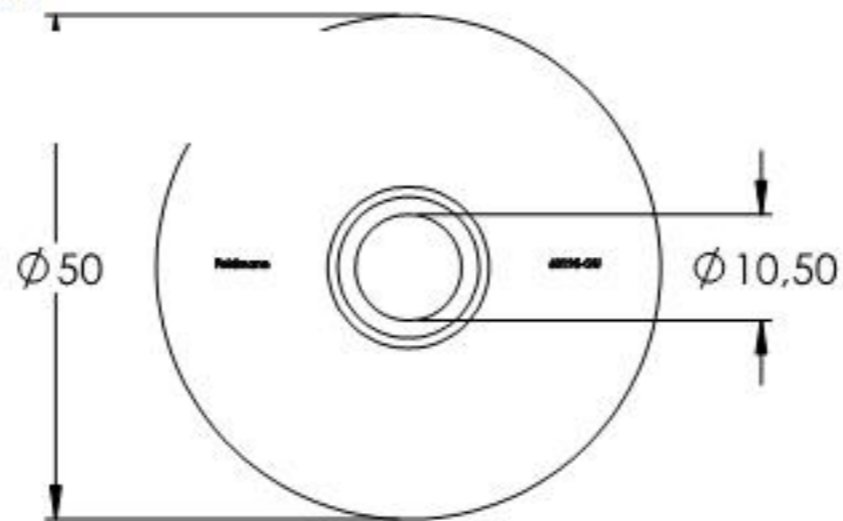
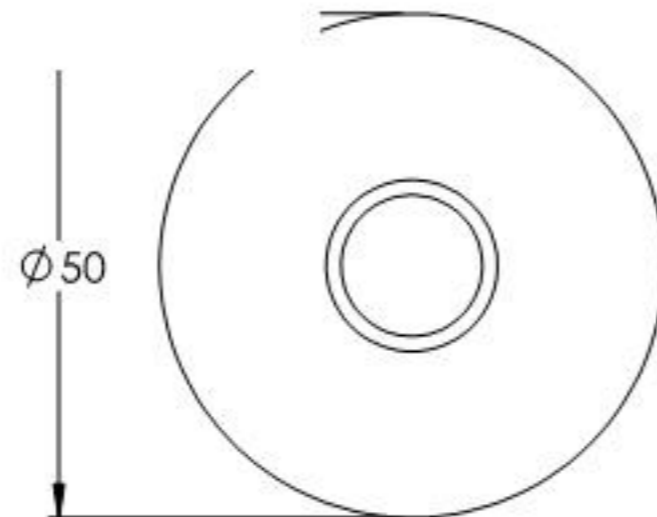
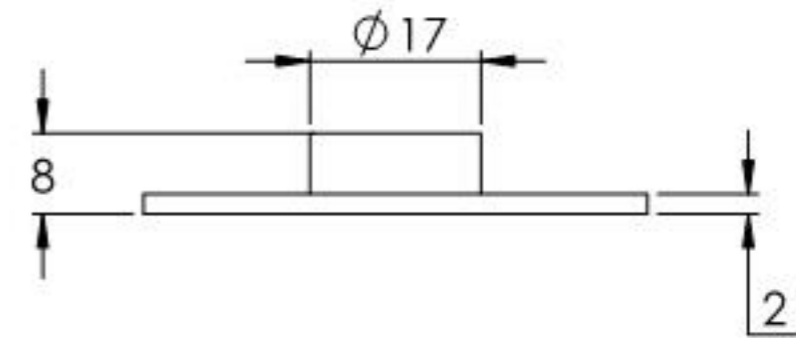
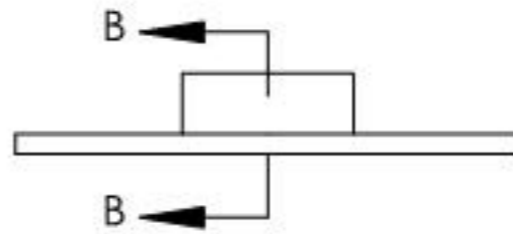
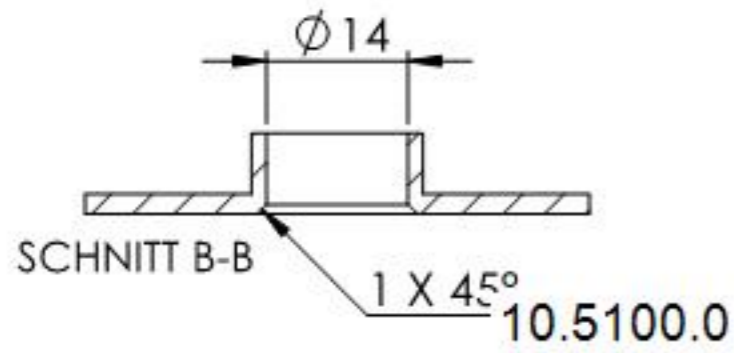
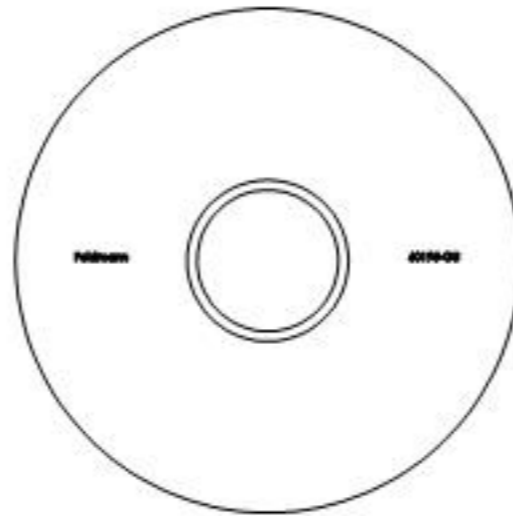

Name	Signatur	Datum	Artikelnummer	Oberfläche: Roh
Ch. Höfig	CH	30.10.2020	60195-GU Teil1	
Werkstoff: EPDM			Hersteller	Blattformat
				A4
Gewicht 0.005 kg			Maßstab: 1:1	Version: 1
			Blatt 2 von 4	

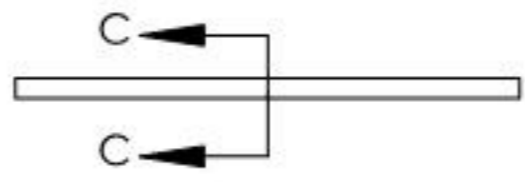
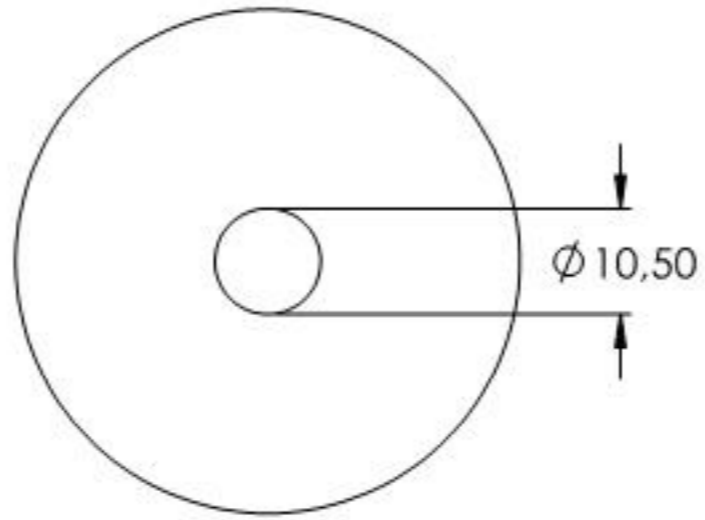

10.5100.0

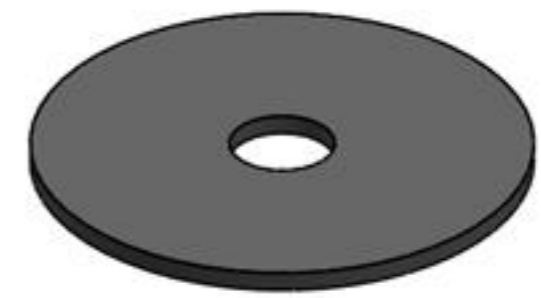
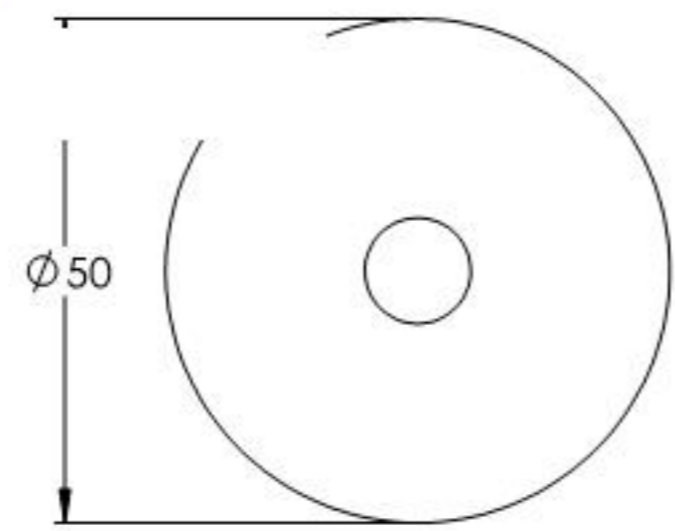

Name	Signatur	Datum	Artikelnummer	Oberfläche: Roh
Ch. Höfig	CH	30.10.2020	60195-GU Teil2	
Werkstoff: EPDM		Hersteller  Feldmann EDLSTAHLE-ALUMINIUM-SCHWEIßEISEN		Blattformat A4
Gewicht 0.004 kg		Maßstab: 1:1	Version: 1	Blatt 3 von 4